



# HIGH SPEED NPN POWER DARLINGTON TRANSISTORS

**D64DV5,6,7  
D64EV5,6,7**

**400-500 VOLTS  
50 AMP, 180 WATTS**

These devices are designed for use in high-speed switching applications, such as off-line switching power supplies, PWM DC & AC motor control, UPS systems, ultrasonic equipment and other high frequency power conversion equipment.

### Features:

- High Speed:  $t_s < 5.0 \mu\text{sec.}$ ,  $t_r < 3.0 \mu\text{sec.}$
- High Voltage: 400-500  $V_{CEO}$
- High Gain:  $h_{FE}$  50 Minimum @ 50 Amperes,  $I_C$
- High Current: 75 Amperes,  $I_C$  (Peak)

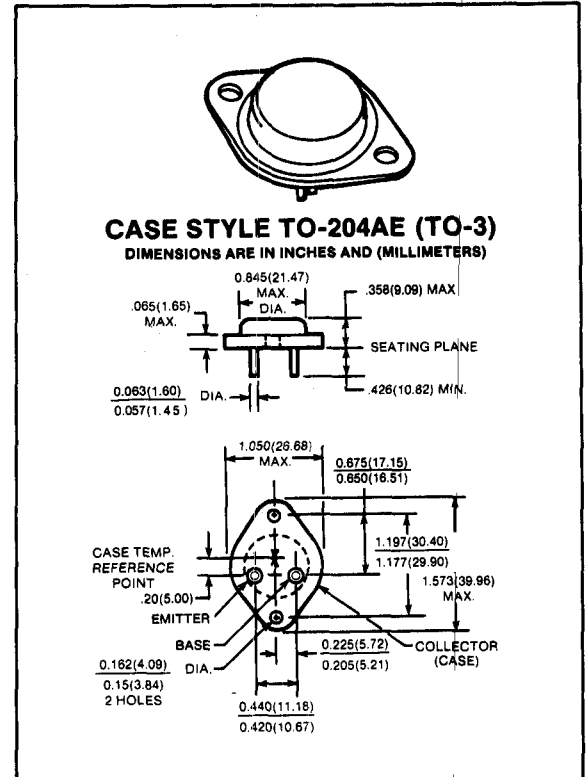
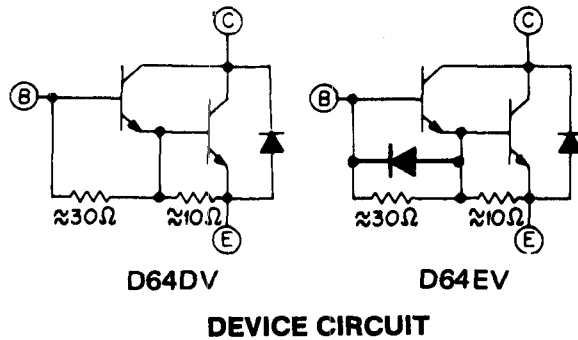

maximum ratings ( $T_C = 25^\circ\text{C}$ ) (unless otherwise noted)

RATING	SYMBOL	D64DV5/EV5	D64DV6/EV6	D64DV7/EV7	UNITS
Collector-Emitter Voltage	$V_{CEO}$	400	450	500	Volts
Collector-Base Voltage	$V_{CBO}$	500	600	700	Volts
Emitter Base Voltage	$V_{EBO}$	8	8	8	Volts
		5	5	5	
Collector Current — Continuous	$I_C$	50	50	50	A
Peak (Repetitive)	$I_{CM}$	75	75	75	
Peak (Non-Repetitive)	$I_{CSM}$	125	125	125	
Base Current — Continuous	$I_B$	10	10	10	A
Peak (Non-Repetitive)	$I_{BM}$	20	20	20	
Total Power Dissipation @ $T_C = 25^\circ\text{C}$	$P_D$	180	180	180	Watts
Operating and Storage Junction Temperature Range	$T_J, T_{STG}$	-65 to +150	-65 to +150	-65 to +150	$^\circ\text{C}$

### thermal characteristics

Thermal Resistance, Junction to Case	$R_{\theta JC}$	0.7	0.7	0.7	$^\circ\text{C/W}$
Maximum Lead Temperature for Soldering Purposes: $\frac{1}{8}$ " from Case for 5 Seconds	$T_L$	300	300	300	$^\circ\text{C}$

electrical characteristics ( $T_C = 25^\circ\text{C}$ ) (unless otherwise specified)

CHARACTERISTIC	SYMBOL	MIN	TYP	MAX	UNIT
----------------	--------	-----	-----	-----	------

off characteristics

Collector-Emitter Sustaining Voltage ( $I_C = .5\text{A}$ ) ( $V_{\text{clamp}} = V_{\text{CEO Rated}}$ )	D64DV5/EV5 D64DV6/EV6 D64DV6/EV7	$V_{\text{CEO(sus)}}$	400 450 500	— — —	— — —	Volts
Collector Cutoff Current ( $V_{\text{CE}} = \text{Rated Value}$ , $V_{\text{BE}} = -1.5\text{V}$ )	$T_J = 25^\circ\text{C}$ $T_J = 150^\circ\text{C}$	$I_{\text{CEV}}$	— —	— —	1.0 2.5	mA
Emitter Cutoff Current ( $V_{\text{EB}} = 4.5\text{V}$ , $I_C = 0$ ) ( $V_{\text{EB}} = 1.5\text{V}$ , $I_C = 0$ )	D64DV D64EV	$I_{\text{EBO}}$	— —	— —	350 350	mA

second breakdown

Second Breakdown with Base Forward Biased	FBSOA	SEE FIGURE 23
---	-------	---------------

on characteristics

DC Current Gain ( $I_C = 75\text{A}$ , $V_{\text{CE}} = 5\text{V}$ ) ( $I_C = 50\text{A}$ , $V_{\text{CE}} = 5\text{V}$ ) ( $I_C = 20\text{A}$ , $V_{\text{CE}} = 5\text{V}$ )	$h_{\text{FE}}$	25 50 100	60 135 250	— — —	—
Collector-Emitter Saturation Voltage ( $I_C = 75\text{A}$ , $I_B = 5\text{A}$ ) ( $I_C = 50\text{A}$ , $I_B = 4\text{A}$ ) ( $I_C = 20\text{A}$ , $I_B = 2\text{A}$ )	$V_{\text{CE(sat)}}$	— — —	2.2 1.7 1.15	3.0 2.0 1.5	V
Base-Emitter Saturation Voltage ( $I_C = 75\text{A}$ , $I_B = 5\text{A}$ ) ( $I_C = 50\text{A}$ , $I_B = 4\text{A}$ ) ( $I_C = 20\text{A}$ , $I_B = 2\text{A}$ )	$V_{\text{BE(sat)}}$	— — —	2.8 2.45 1.95	3.5 3.0 2.5	V

switching characteristics

		TYP.		MAX.			
Resistive Load		DV	EV	DV	EV		
Delay Time	$V_{\text{CC}} = 250\text{V}$	$t_d$	—	0.09	.09	.5	$\mu\text{s}$
Rise Time	$I_C = 50\text{A}$	$t_r$	—	.5	.5	1	
Storage Time	$I_{B1} = 2.5\text{A}$ , $I_{B2} = 5\text{A}$	$t_s$	—	2.55	2	5	
Fall Time	$t_p = 50 \mu\text{sec}$	$t_f$	—	1.4	.64	3	

emitter-collector diode characteristics

Power Dissipation ( $I_{B1} = 0$ )	$P_D$	—	—	125	Watts
Forward Voltage ( $I_F = 25\text{A}$ ) ( $I_F = 50\text{A}$ ) ( $I_F = 50\text{A}$ , $T_J = 150^\circ\text{C}$ )	$V_F$ $V_F$ $V_F$	— — —	1.95 2.60 2.30	3.20 3.80 3.50	Volts Volts Volts
Reverse Recovery Time ( $I_F = 50\text{A}$ , $di/dt = 25\text{A}/\mu\text{sec}$ , $R_{B1E} = .25\Omega$ )	$T_{rr}$	—	3.85	10.0	$\mu\text{sec}$
Forward Turn-On Time ( $I_F = 100\text{A}$ , $di/dt = 100\text{A}/\mu\text{sec}$ )	$T_{\text{ON}}$	—	0.75	1.5	$\mu\text{sec}$
Single Cycle Surge Current (60Hz)	$I_{\text{FSM}}$	—	—	150	Amps
Thermal Resistance	$R_{\theta\text{JC}}$	—	—	1.0	$^\circ\text{C}/\text{Watt}$

## TYPICAL CHARACTERISTICS

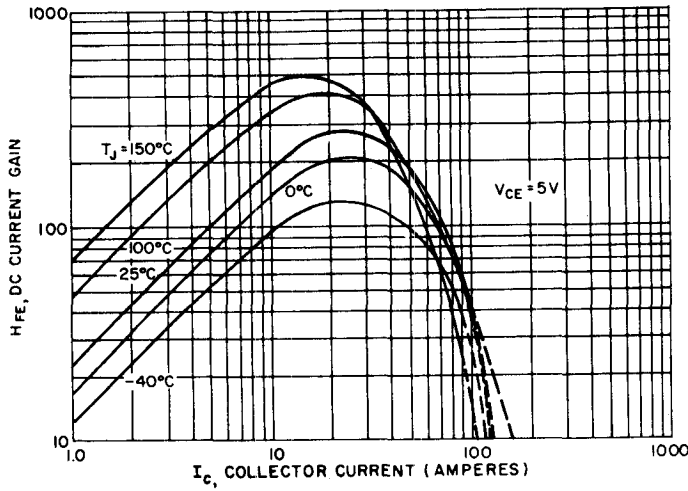

**FIGURE 1. DC CURRENT GAIN ( $V_{CE} = 5V$ )**

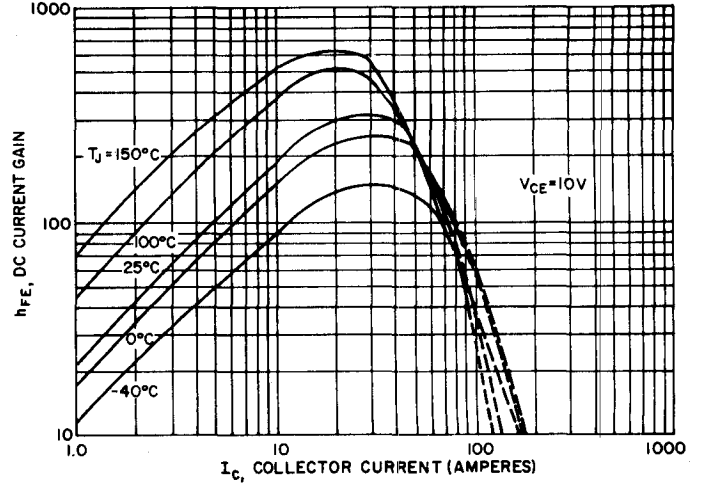

**FIGURE 2. DC CURRENT GAIN ( $V_{CE} = 10V$ )**

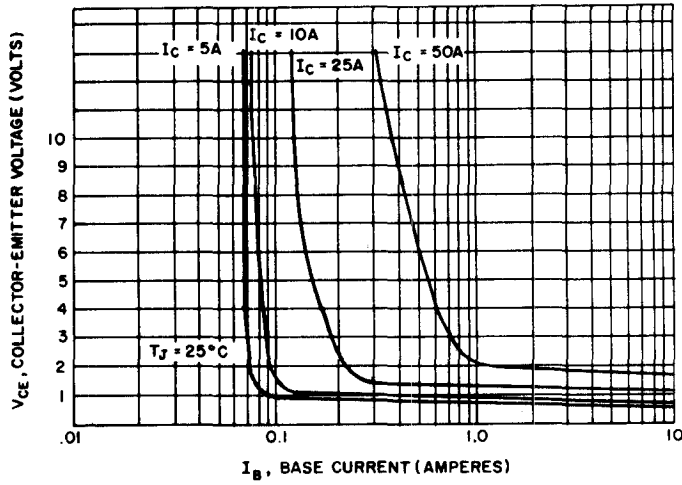

**FIGURE 3. COLLECTOR SATURATION REGION**

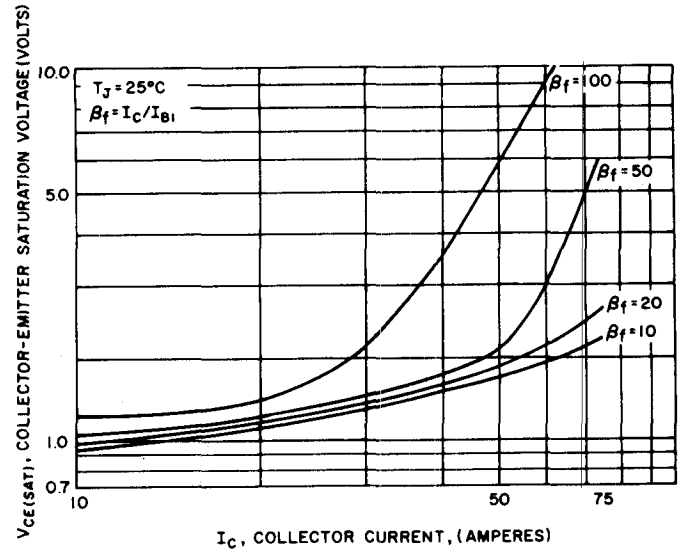

**FIGURE 4.  $V_{CE} (SAT)$  VS  $I_C$ ,  $T_J = 25^\circ C$**

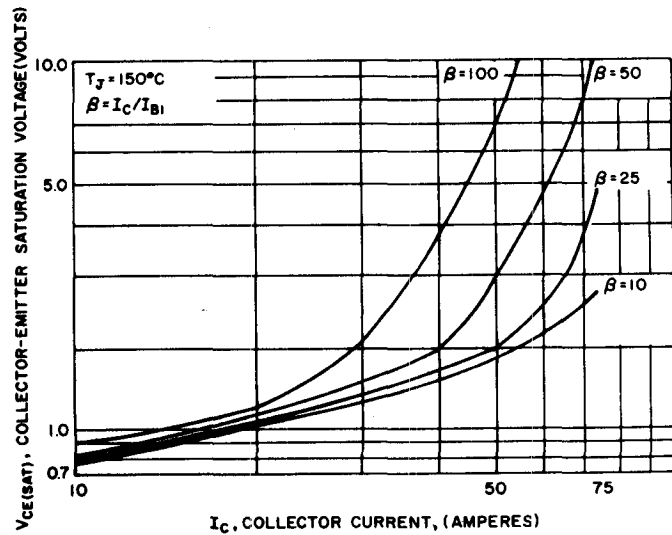

**FIGURE 5.  $V_{CE} (SAT)$  VS  $I_C$ ,  $T_J = 150^\circ C$**

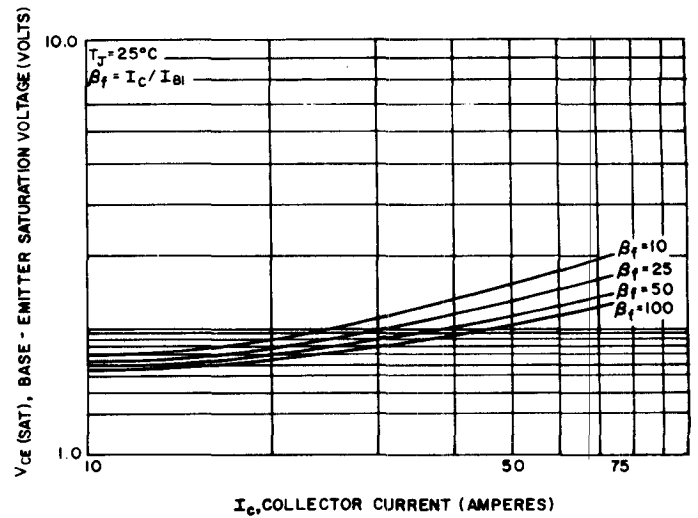

**FIGURE 6.  $V_{BE} (SAT)$  VS  $I_C$ ,  $T_J = 25^\circ C$**

# TYPICAL CHARACTERISTICS

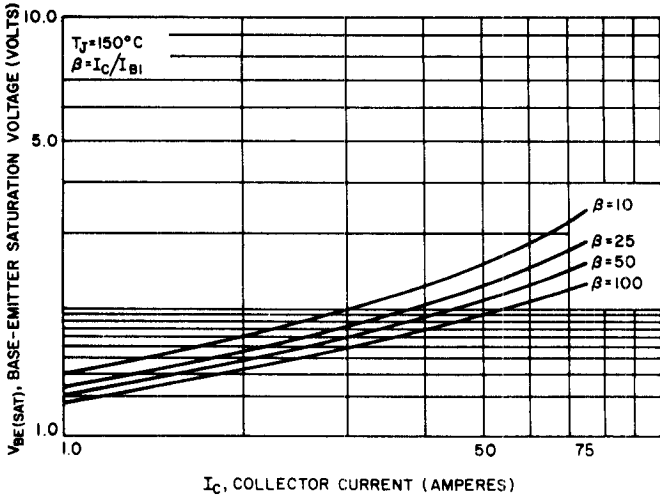

FIGURE 7.  $V_{BE(SAT)}$  VS  $I_C$ ,  $T_J = 150^\circ\text{C}$

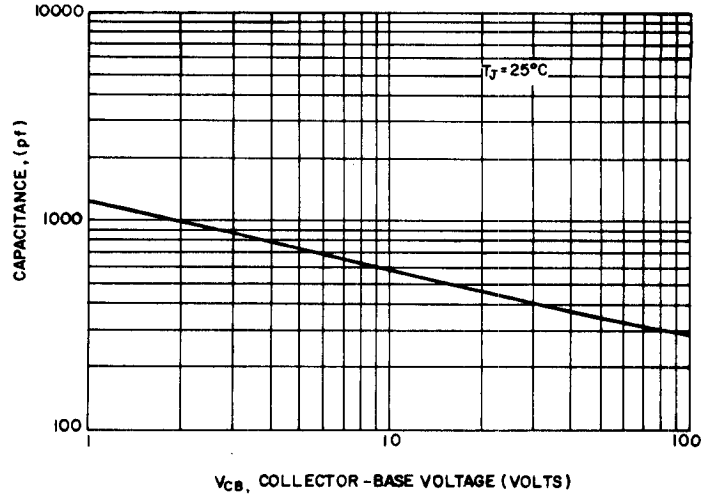

FIGURE 8. CAPACITANCE ( $C_{CBO}$ )

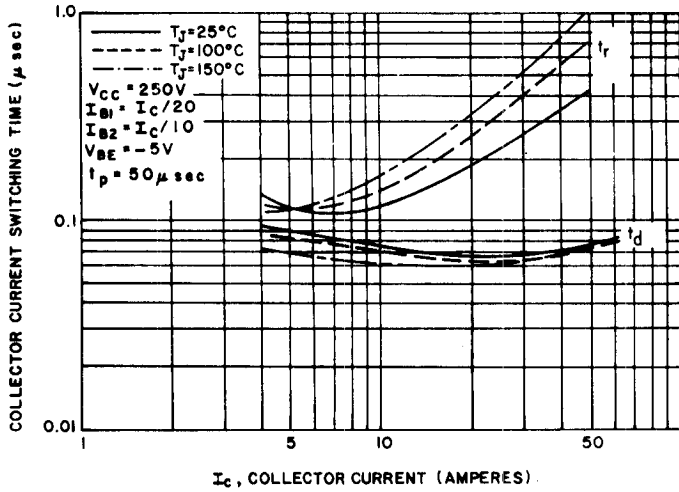

FIGURE 9. TURN-ON TIME (RESISTIVE LOAD) (D64DV ONLY)

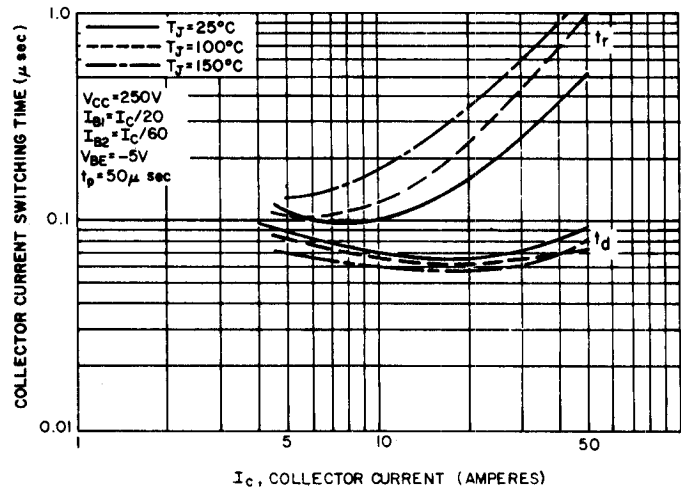

FIGURE 10. TURN-ON TIME (RESISTIVE LOAD) (D64EV ONLY)

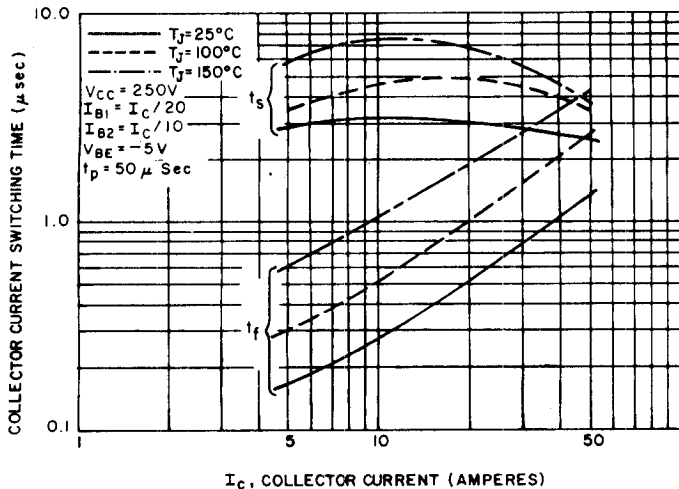

FIGURE 11. TURN-OFF TIME (RESISTIVE LOAD) (D64DV ONLY)

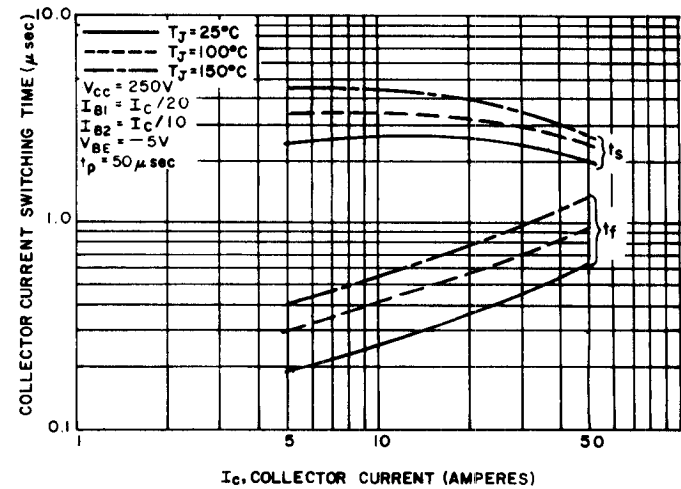
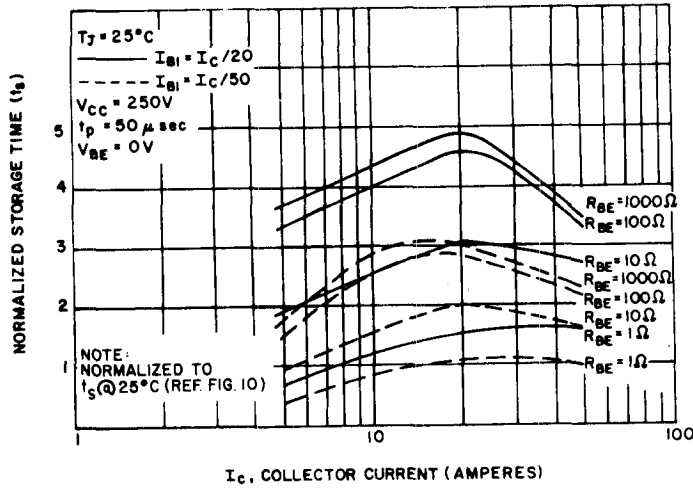
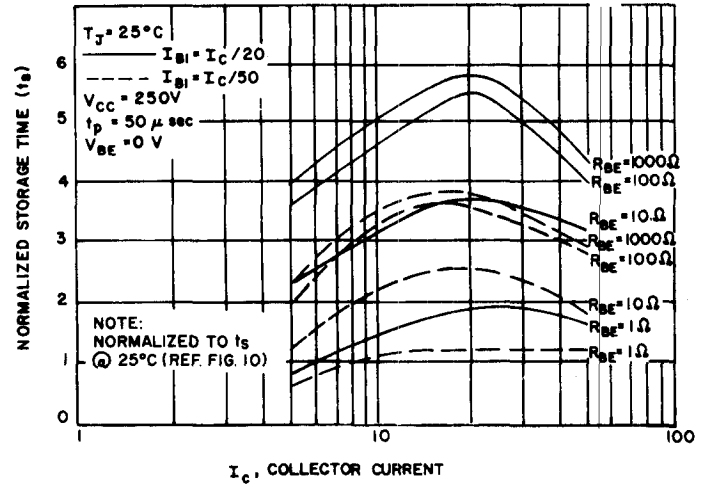

FIGURE 12. TURN-OFF TIME (RESISTIVE LOAD) (D64EV ONLY)

# TYPICAL CHARACTERISTICS



**FIGURE 13. NORMALIZED RESISTIVE SWITCHING STORAGE TIME ( $R_{BE}$  VARIATIONS) VS COLLECTOR CURRENT (D64DV ONLY)**



**FIGURE 14. NORMALIZED RESISTIVE SWITCHING STORAGE TIME ( $R_{BE}$  VARIATIONS) VS COLLECTOR CURRENT (D64EV ONLY)**

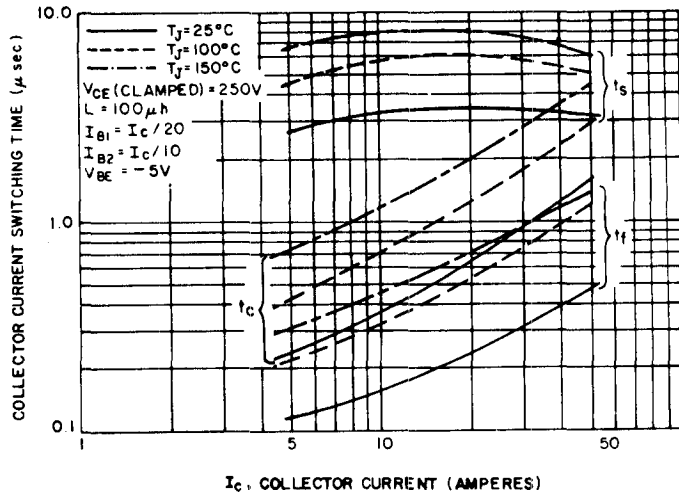

**FIGURE 15. CLAMPING INDUCTIVE TURN-OFF TIME (D64DV ONLY)**

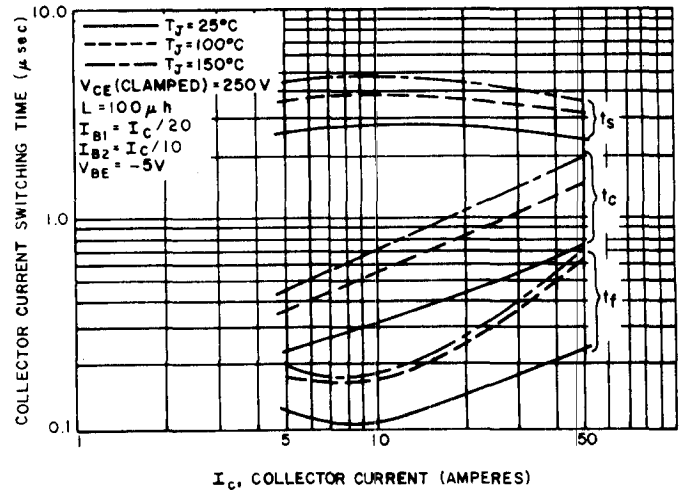

**FIGURE 16. CLAMPING INDUCTIVE TURN-OFF TIME (D64EV ONLY)**

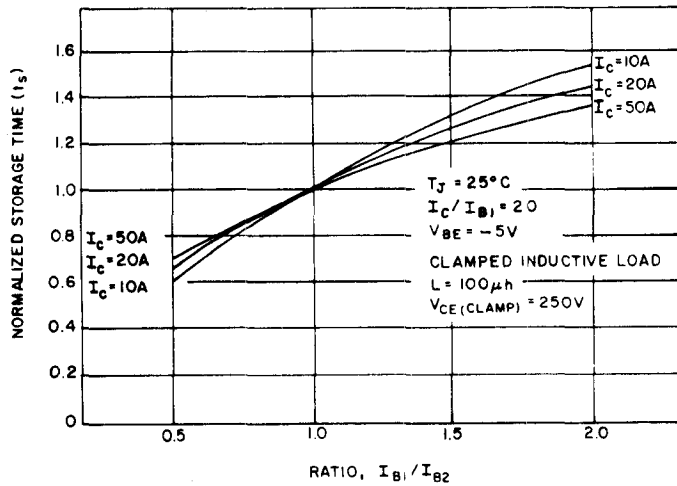

**FIGURE 17. STORAGE TIME VARIATION WITH  $I_{B2}$  (D64DV ONLY)**

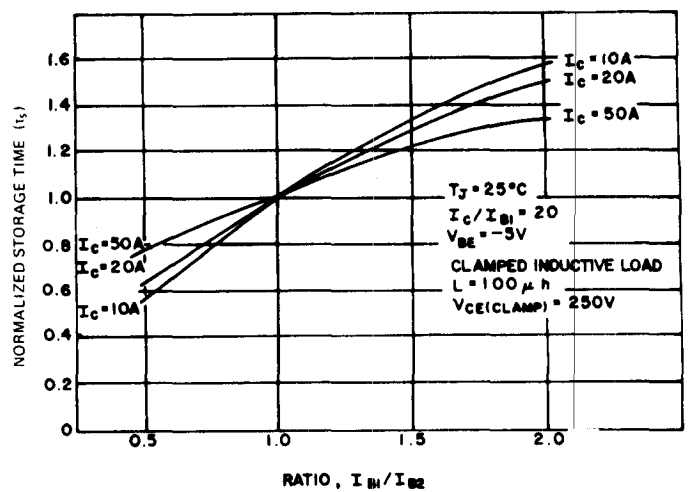

**FIGURE 18. STORAGE TIME VARIATION WITH  $I_{B2}$  (D64EV ONLY)**

# TYPICAL CHARACTERISTICS

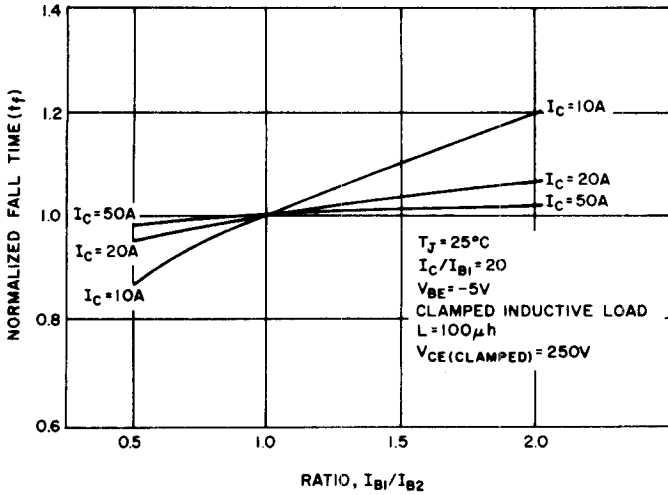

FIGURE 19. FALL TIME VARIATION WITH  $I_{B2}$  (D64DV ONLY)

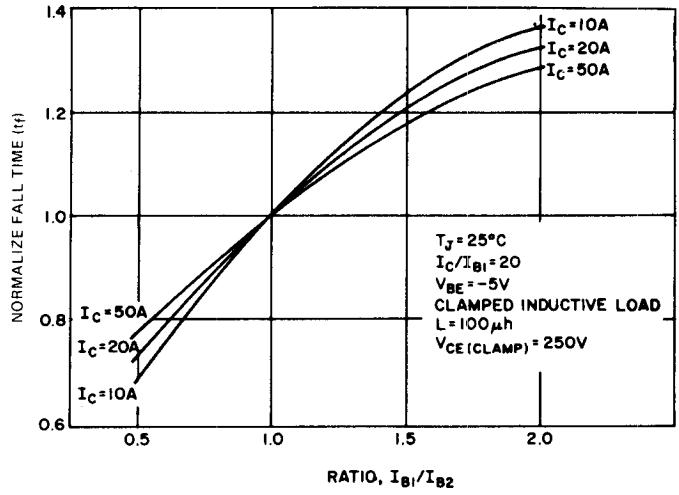

FIGURE 20. FALL TIME VARIATION WITH  $I_{B2}$  (D64EV ONLY)

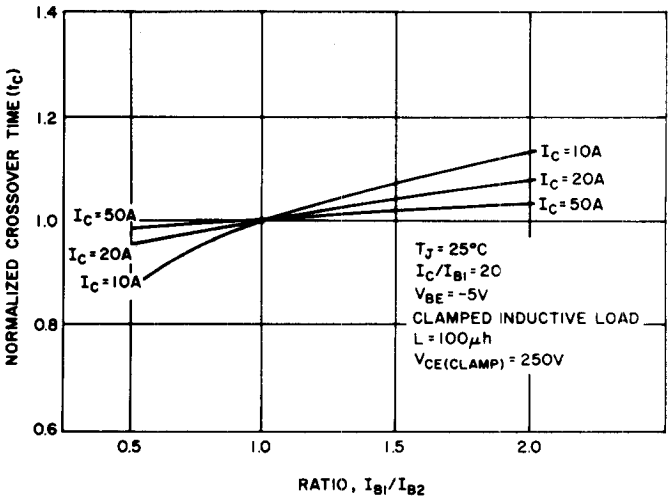

FIGURE 21. CROSSOVER TIME VARIATION WITH  $I_{B2}$  (D64DV ONLY)

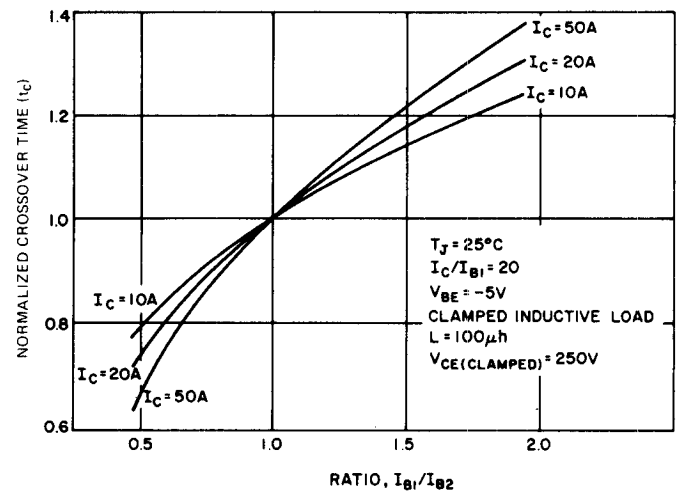

FIGURE 22. CROSSOVER TIME VARIATION WITH  $I_{B2}$  (D64EV ONLY)

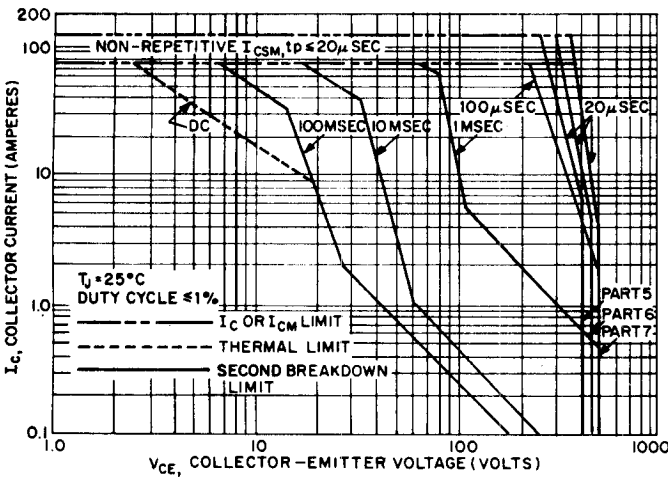

FIGURE 23. FORWARD BIAS SAFE OPERATING AREA

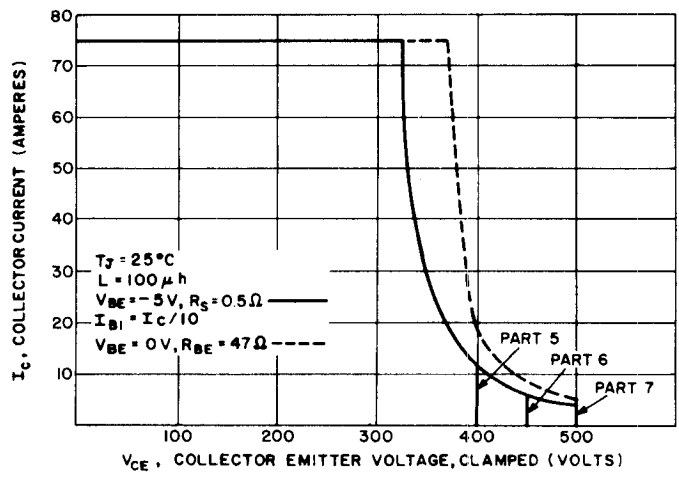

FIGURE 24. REVERSE BIAS SAFE OPERATING AREA (CLAMPED)

# TYPICAL CHARACTERISTICS

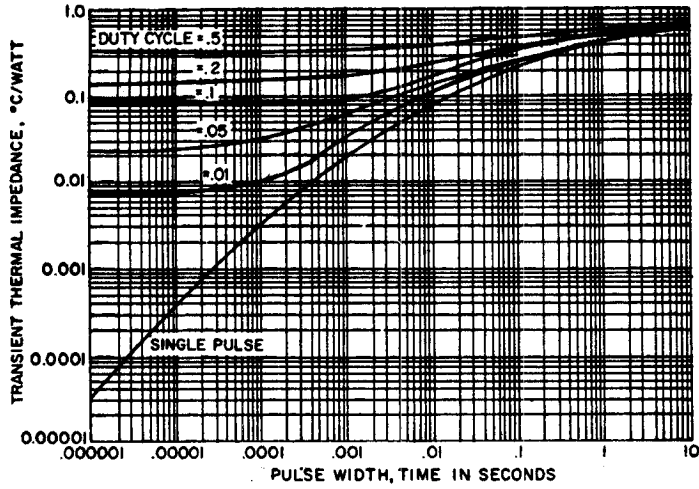

FIGURE 25. TRANSIENT THERMAL RESPONSE

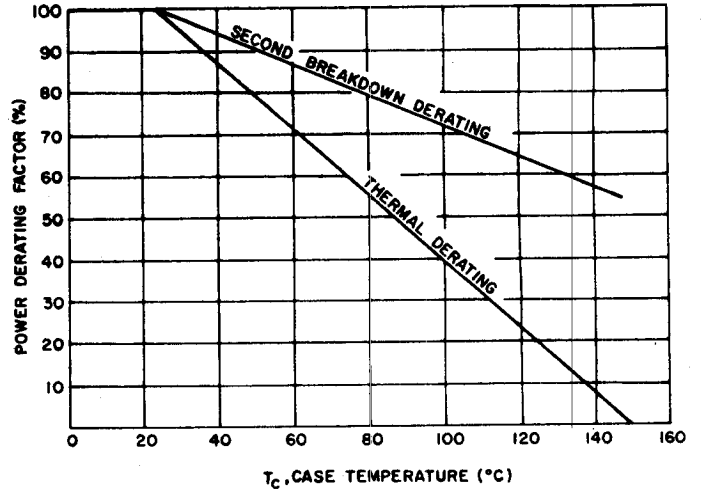

FIGURE 26. POWER DERATING

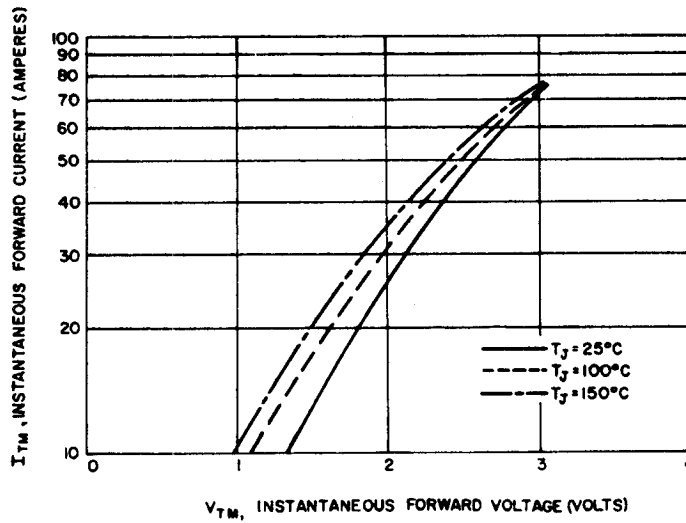

FIGURE 27. FORWARD CHARACTERISTICS

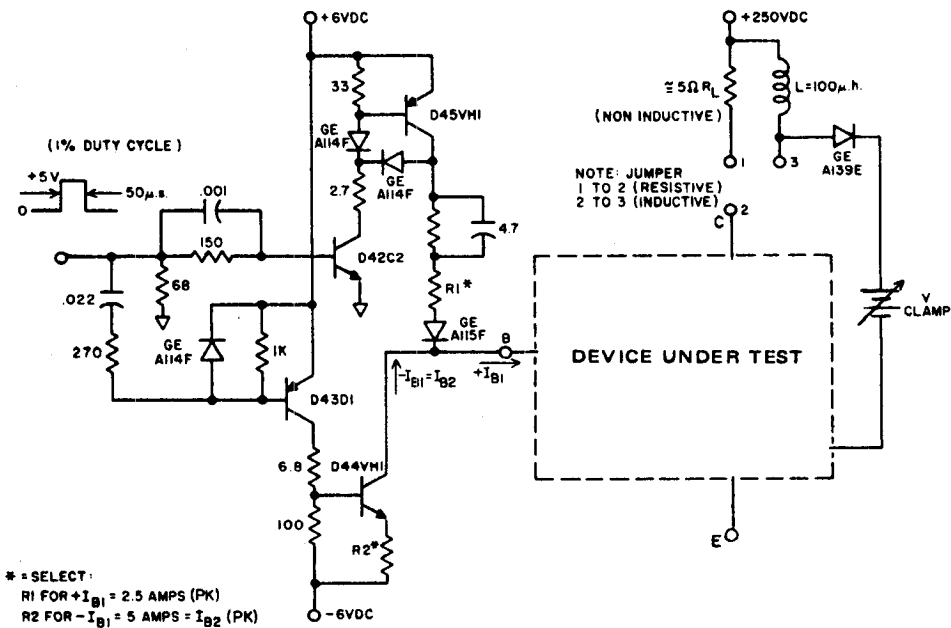

FIGURE 28. SWITCHING TIME TEST CIRCUIT