



# HIGH SPEED NPN POWER DARLINGTON TRANSISTORS

**D66GV5,6,7**

**400-500 VOLTS  
50 AMP, 125 WATTS**

The D66GV is a high voltage NPN high current power darlington especially designed for use in PWM applications where fast and efficient switching is required. This device utilizes GE's latest advances in bipolar technology and features the D66 Package offering: collector isolation from heat sink, TO-3 mounting compatibility and quick-connect terminals.

The D66GV also features a discrete fast recovery antiparallel high power diode which eliminates the need for an external flyback diode in motor control and other inverter applications such as power supplies and UPS systems.

**Features:**

- Fast switching —  $t_f(\text{TYP})$  0.5  $\mu\text{s}$
- High blocking voltage —  $V_{CEV}$  500 to 700 Volts
- High current —  $I_C(\text{Peak})$  75 Amps
- High gain —  $h_{FE}(\text{MIN})$  50 @ 50 Amps
- Discrete high power fast recovery diode
- UL recognized isolated base package

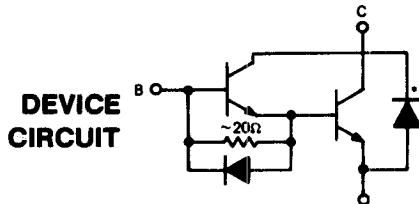

\*NOTE: The collector-emitter diode is a discrete fast-recovery high power diode.

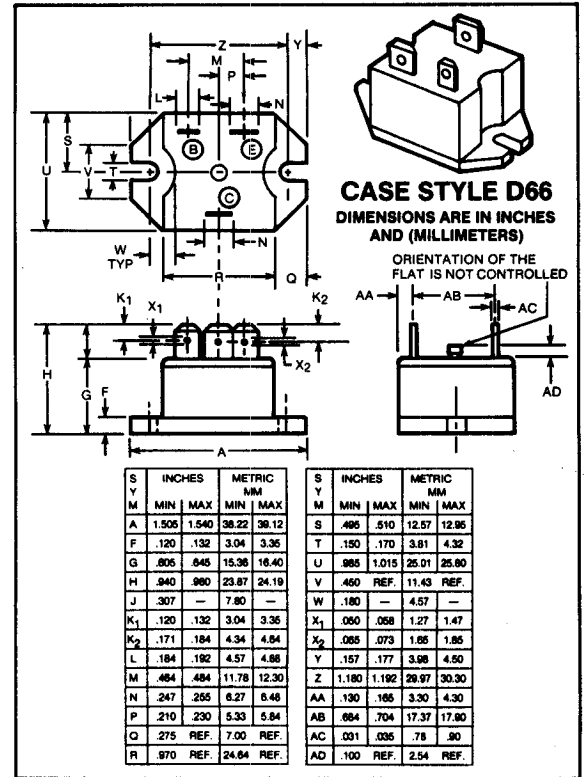

maximum ratings ( $T_C = 25^\circ\text{C}$ ) (unless otherwise noted)

RATING	SYMBOL	D66GV5	D66GV6	D66GV7	UNITS
Collector-Emitter Voltage	$V_{CEV}$	500	600	700	Volts
Collector-Emitter Voltage	$V_{CER}$	400	450	500	Volts
Emitter Base Voltage	$V_{EBO}$	7	7	7	Volts
Collector Current — Continuous	$I_C$	50	50	50	A
Peak (Repetitive)	$I_{CM}$	75	75	75	
Peak (Non-Repetitive)	$I_{CSM}$	125	125	125	
Base Current — Continuous	$I_B$	10	10	10	A
Peak (Non-Repetitive)	$I_{BM}$	20	20	20	
Total Power Dissipation @ $T_C = 25^\circ\text{C}$	$P_D$	125	125	125	Watts
Derate above $25^\circ\text{C}$		1.0	1.0	1.0	$\text{W}/^\circ\text{C}$
Operating and Storage Junction Temperature Range	$T_J, T_{STG}$	-40 to +150	-40 to +150	-40 to +150	$^\circ\text{C}$
Isolation Voltage	$V_{ISOL}$	2500	2500	2500	$V_{(rms)}$

**thermal characteristics**

Thermal Resistance, (transistor)	$R_{\theta JC}$	1.0	1.0	1.0	$^\circ\text{C}/\text{W}$
(diode)		2.5	2.5	2.5	

(1) Pulse Test: Pulse Width = 300 ms. Duty Cycle  $\leq$  2%.

See page 845 for mounting and handling considerations.

electrical characteristics ( $T_C = 25^\circ\text{C}$ ) (unless otherwise specified)

CHARACTERISTIC	SYMBOL	MIN	TYP	MAX	UNIT
----------------	--------	-----	-----	-----	------

off characteristics

Collector-Emitter Sustaining Voltage ( $I_C = 1\text{A}$ , $R_{BE} = 10\Omega$ )	D66GV5 D66GV6 D66GV7	$V_{CEO(sus)}$	400 450 550	— — —	— — —	Volts
Collector Cutoff Current ( $V_{CE} = \text{Rated } V_{CEV}$ , $V_{BE(off)} = 1.5\text{V}$ )	$T_J = 25^\circ\text{C}$ $T_J = 150^\circ\text{C}$	$I_{CEV}$	— —	— —	1.0 2.5	mA
Emitter Cutoff Current ( $V_{EB} = 5\text{V}$ , $I_C = 0$ )		$I_{EBO}$	—	—	10	mA

second breakdown

Second Breakdown with Base Forward Biased	FBSOA	SEE FIGURE 24
---	-------	---------------

on characteristics

DC Current Gain ( $I_C = 75\text{A}$ , $V_{CE} = 5\text{V}$ ) ( $I_C = 50\text{A}$ , $V_{CE} = 5\text{V}$ ) ( $I_C = 20\text{A}$ , $V_{CE} = 5\text{V}$ )	$h_{FE}$	25 50 100	150 300 350	— — —	—
Collector-Emitter Saturation Voltage ( $I_C = 75\text{A}$ , $I_B = 5\text{A}$ ) ( $I_C = 50\text{A}$ , $I_B = 4\text{A}$ ) ( $I_C = 20\text{A}$ , $I_B = 2\text{A}$ )	$V_{CE(sat)}$	— — —	1.6 1.3 1.0	3.0 2.0 1.5	V
Base-Emitter Saturation Voltage ( $I_C = 75\text{A}$ , $I_B = 5\text{A}$ ) ( $I_C = 50\text{A}$ , $I_B = 4\text{A}$ ) ( $I_C = 20\text{A}$ , $I_B = 2\text{A}$ )	$V_{BE(sat)}$	— — —	2.2 2.0 —	3.5 3.0 2.5	V V V

switching characteristics

Resistive Load						
Delay Time	$V_{CE} = 250\text{V}$ $I_C = 50\text{A}$ $I_{B1} = 2.5\text{A}$ , $I_{B2} = 5\text{A}$ $PW = 50\ \mu\text{sec}$	$t_d$	—	0.1	0.5	$\mu\text{s}$
Rise Time		$t_r$	—	6.5	1.0	
Storage Time		$t_s$	—	2.5	3.0	
Fall Time		$t_f$	—	0.6	0.75	

emitter-collector diode characteristics

Forward Voltage @ $T_J = 25^\circ\text{C}$ @ $T_J = 150^\circ\text{C}$	( $I_F = 25\text{A}$ )	$V_P$ $V_P$	— —	1.3 1.3	2.0 2.5	Volts Volts
Reverse Recovery Time ( $I_F = 50\text{A}$ , $di/dt = 100\text{A}/\mu\text{sec}$ , $V_{BE(off)} = 1.5\text{V}$ )		$T_{rr}$	—	0.5	1.0	$\mu\text{sec}$

## TYPICAL CHARACTERISTICS

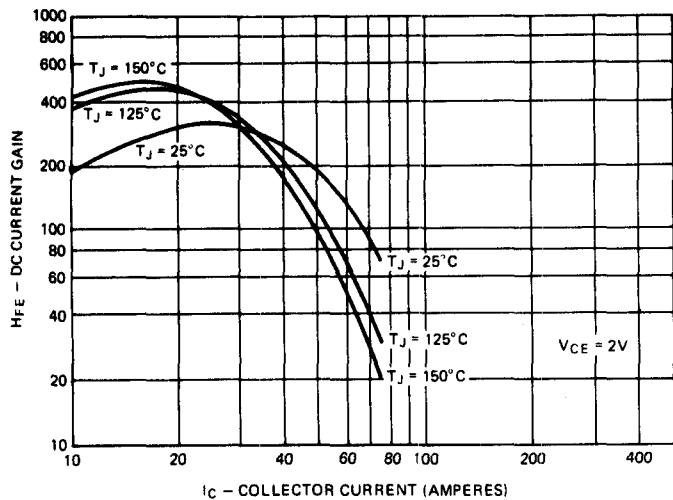

**FIGURE 1. DC CURRENT GAIN ( $V_{CE} = 2V$ ), TYPICAL**

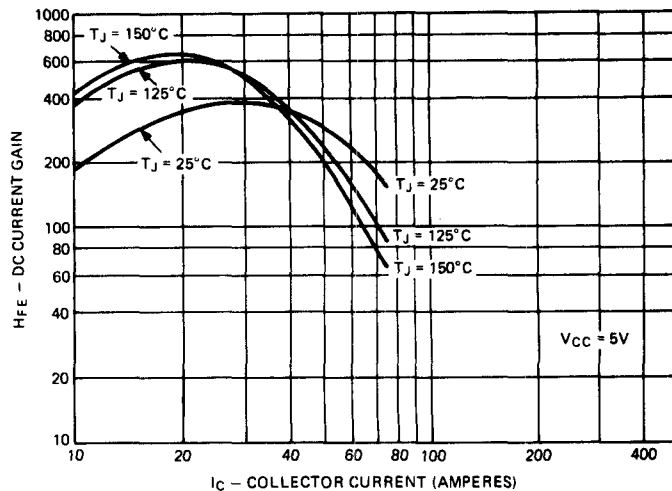

**FIGURE 2. DC CURRENT GAIN ( $V_{CE} = 5V$ ), TYPICAL**

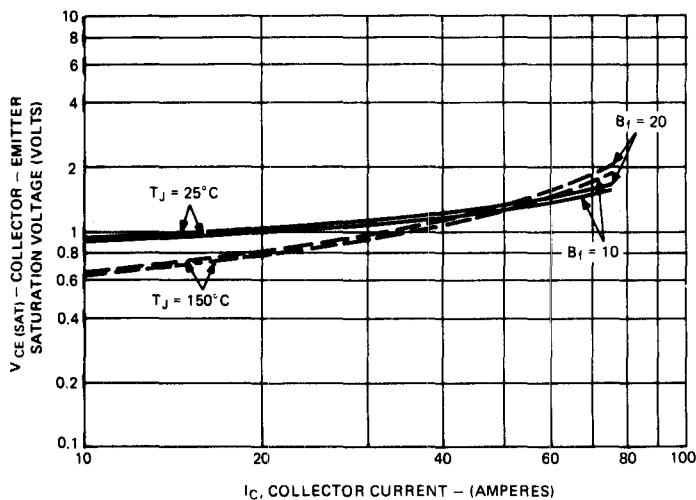

**FIGURE 3.  $V_{CE(SAT)}$  vs.  $I_C$ , TYPICAL**

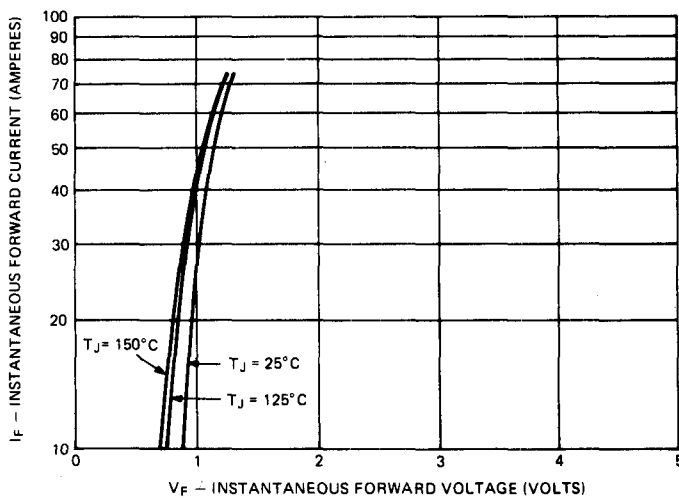

**FIGURE 4. DIODE FORWARD CHARACTERISTICS**

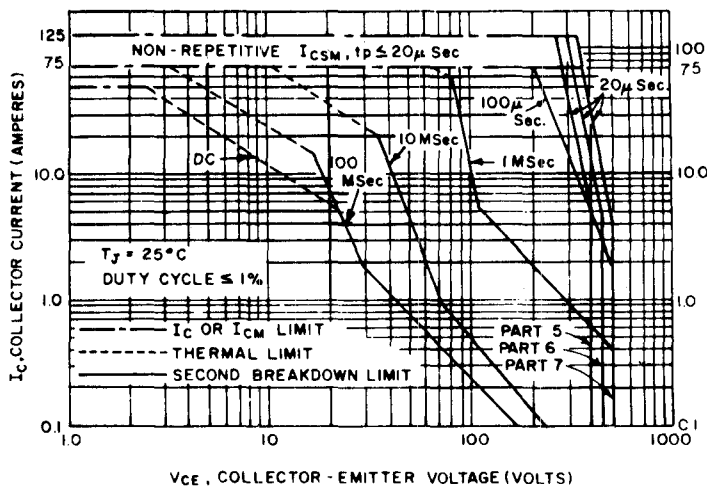

**FIGURE 5. FORWARD BIAS SAFE OPERATING AREA**

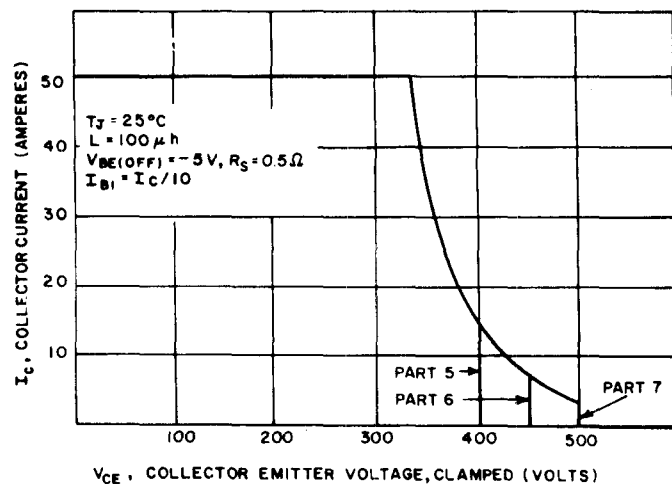

**FIGURE 6. REVERSE BIAS SAFE OPERATING AREA (CLAMPED)**

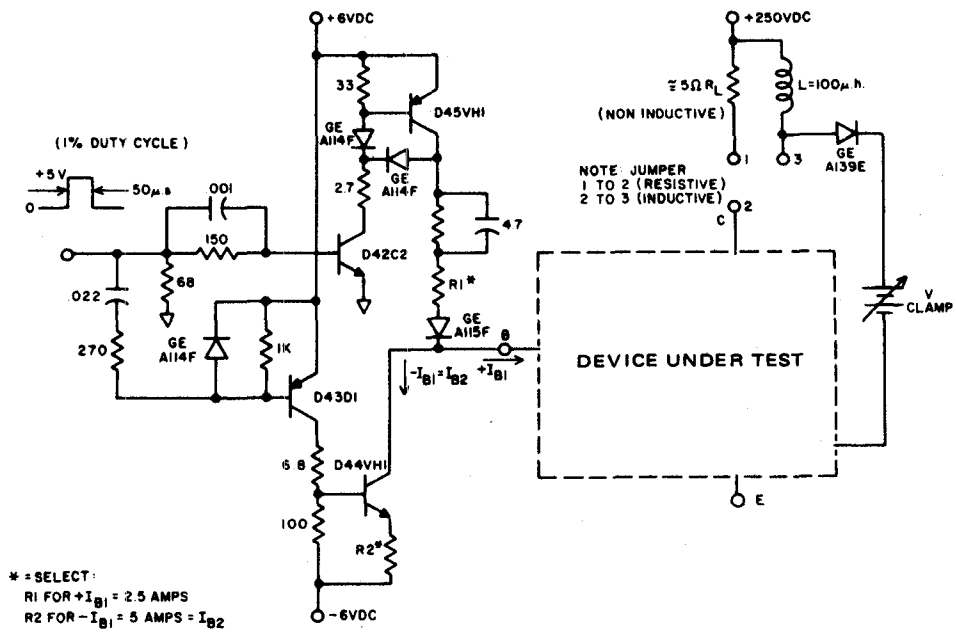

FIGURE 7. SWITCHING TIME TEST CIRCUIT