

Elektrische Eigenschaften / Electrical properties

Höchstzulässige Werte / Maximum rated values

Periodische Spitzensperrspannung repetitive peak reverse voltage	$T_{vj} = -40^{\circ}\text{C} \dots T_{vj\text{max}}$	V_{RRM}	1200, 1400 1600, 1800	V V
Stoßspitzensperrspannung non-repetitive peak reverse voltage	$T_{vj} = +25^{\circ}\text{C} \dots T_{vj\text{max}}$	V_{RSM}	1300, 1500 1700, 1900	V V
Durchlaßstrom-Grenzeffektivwert (pro Element) RMS forward current (per chip)		I_{FRMSM}	60	A
Ausgangsstrom output current	$T_C = 100^{\circ}\text{C}$ $T_C = 84^{\circ}\text{C}$ $T_A = 45^{\circ}\text{C}$, KM 11 $T_A = 45^{\circ}\text{C}$, KM 33 $T_A = 35^{\circ}\text{C}$, KM 14 ($V_L = 45\text{l/s}$) $T_A = 35^{\circ}\text{C}$, KM 33 ($V_L = 90\text{l/s}$)	I_d	85 104 58 75 104 104	A A A A A A
Stoßstrom-Grenzwert surge forward current	$T_{vj} = 25^{\circ}\text{C}$, $t_p = 10\text{ms}$ $T_{vj} = T_{vj\text{max}}$, $t_p = 10\text{ms}$	I_{FSM}	650 550	A A
Grenzlastintegral I^2t -value	$T_{vj} = 25^{\circ}\text{C}$, $t_p = 10\text{ms}$ $T_{vj} = T_{vj\text{max}}$, $t_p = 10\text{ms}$	I^2t	2100 1500	A^2s A^2s

Charakteristische Werte / Characteristic values

Durchlaßspannung forward voltage	$T_{vj} = T_{vj\text{max}}$, $i_F = 100\text{A}$	V_F	max. 1,44	V
Schleusenspannung threshold voltage	$T_{vj} = T_{vj\text{max}}$	$V_{(TO)}$	0,75	V
Ersatzwiderstand forward slope resistance	$T_{vj} = T_{vj\text{max}}$	r_T	5,5	$\text{m}\Omega$
Sperrstrom reverse current	$T_{vj} = T_{vj\text{max}}$, $V_R = V_{RRM}$	i_R	max. 5	mA
Isolations-Prüfspannung insulation test voltage	RMS, $f = 50\text{Hz}$, $t = 1\text{min}$ RMS, $f = 50\text{Hz}$, $t = 1\text{sec}$	V_{ISOL}	3,0 3,6	kV kV

Thermische Eigenschaften / Thermal properties

Innerer Wärmewiderstand thermal resistance, junction to case	pro Modul / per module, $\Theta = 120^{\circ}\text{rect}$ pro Element / per chip, $\Theta = 120^{\circ}\text{rect}$ pro Modul / per module, DC pro Element / per chip, DC	R_{thJC}	max. 0,241 max. 1,450 max. 0,183 max. 1,100	$^{\circ}\text{C/W}$ $^{\circ}\text{C/W}$ $^{\circ}\text{C/W}$ $^{\circ}\text{C/W}$
Übergangs-Wärmewiderstand thermal resistance, case to heatsink	pro Modul / per module pro Element / per chip	R_{thCK}	max. 0,033 max. 0,200	$^{\circ}\text{C/W}$ $^{\circ}\text{C/W}$
Höchstzulässige Sperrschichttemperatur max. junction temperature		$T_{vj\text{max}}$	150	$^{\circ}\text{C}$
Betriebstemperatur operating temperature		$T_{c\text{op}}$	-40...+150	$^{\circ}\text{C}$
Lagertemperatur storage temperature		T_{stg}	-40...+150	$^{\circ}\text{C}$

Mechanische Eigenschaften / Mechanical properties

Gehäuse, siehe Anlage case, see appendix			Seite 3 page 3	
Si-Elemente mit Lötkontakt, glaspassiviert Si-pellets with soldered contact, glass-passivated				
Innere Isolation internal insulation			Al ₂ O ₃	
Anzugsdrehmoment für mechanische Befestigung mounting torque	Toleranz / tolerance ±15%	M1	6	Nm
Anzugsdrehmoment für elektrische Anschlüsse terminal connection torque	Toleranz / tolerance +5% / -10%	M2	4	Nm
Gewicht weight		G	typ. 220	g
Kriechstrecke creepage distance			12,5	mm
Schwingfestigkeit vibration resistance	f = 50Hz		50	m/s ²

Kühlkörper / heatsinks : KM 11; KM 14; KM 17; KM 33

Mit dieser technischen Information werden Halbleiterbauelemente spezifiziert, jedoch keine Eigenschaften zugesichert. Sie gilt in Verbindung mit den zugehörigen Technischen Erläuterungen. / This technical information specifies semiconductor devices but promises no characteristics. It is valid in combination with the belonging technical notes.

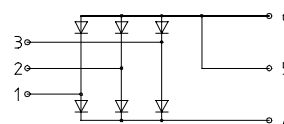
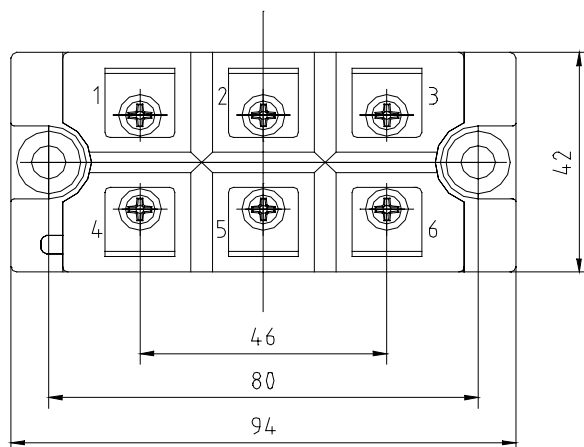
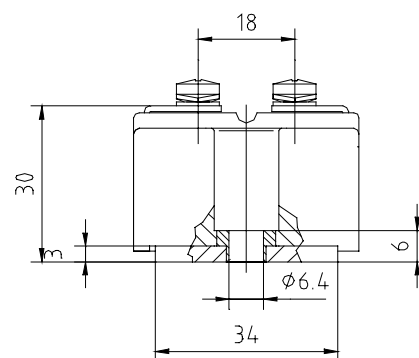
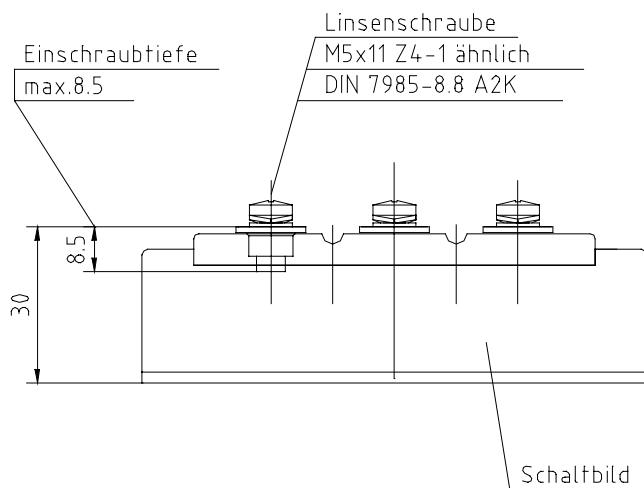

Analytische Elemente des transienten Wärmewiderstandes Z_{thJC} für DC Analytical elements of transient thermal impedance Z_{thJC} for DC							
Pos. n	1	2	3	4	5	6	7
$R_{thn} [^{\circ}C / W]$	0,60300	0,35000	0,06700	0,08400			
$\tau_n [s]$	0,30200	0,03780	0,00400	0,00109			
Analytische Funktion: $Z_{thJC} = \sum_{n=1}^{n_{max}} R_{thn} \left(1 - e^{-\frac{t}{\tau_n}} \right)$							

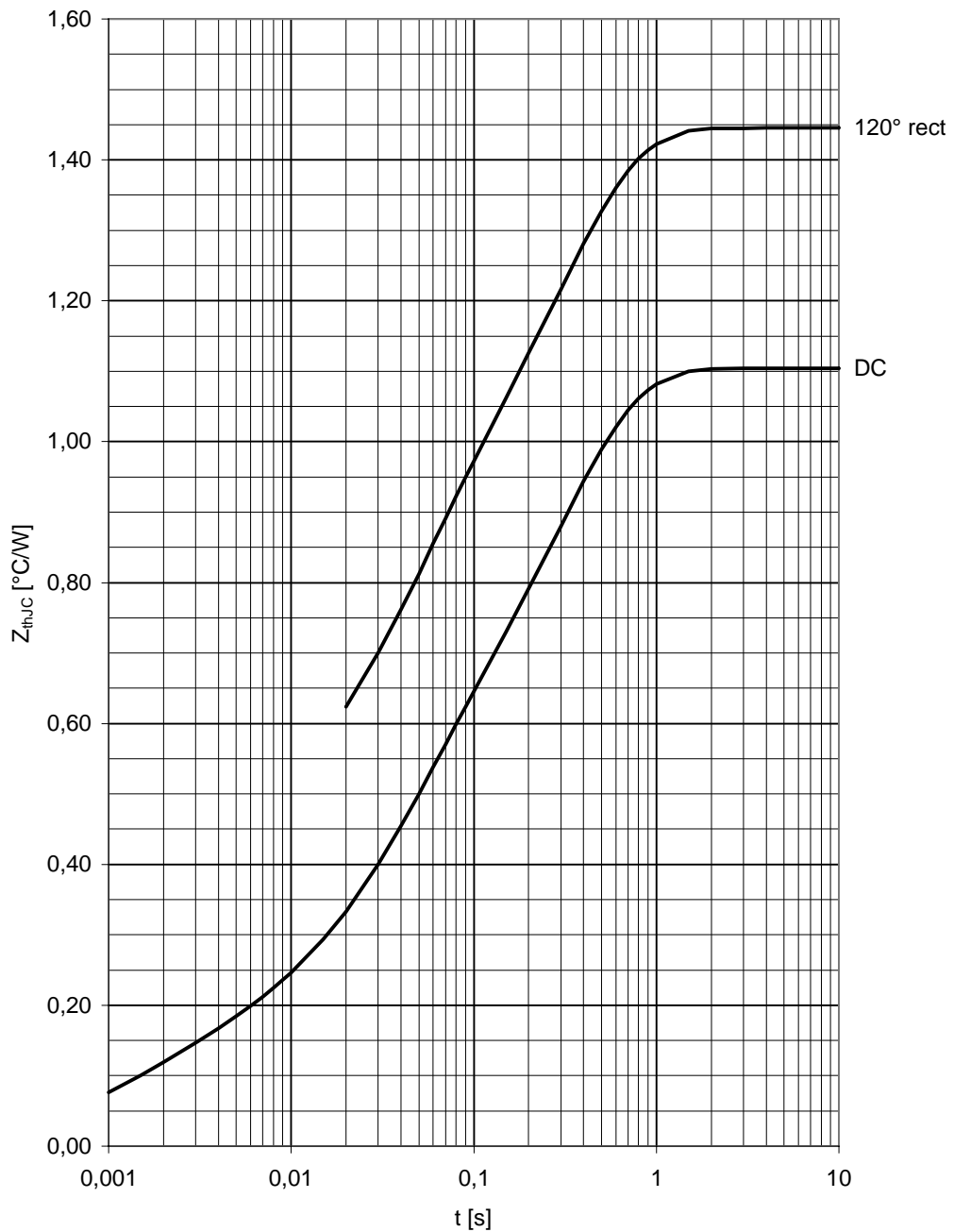

Transienter innerer Wärmewiderstand je Zweig / Transient thermal impedance per arm, $Z_{thJC} = f(t)$
 Parameter: Stromflußwinkel / Current conduction angle α

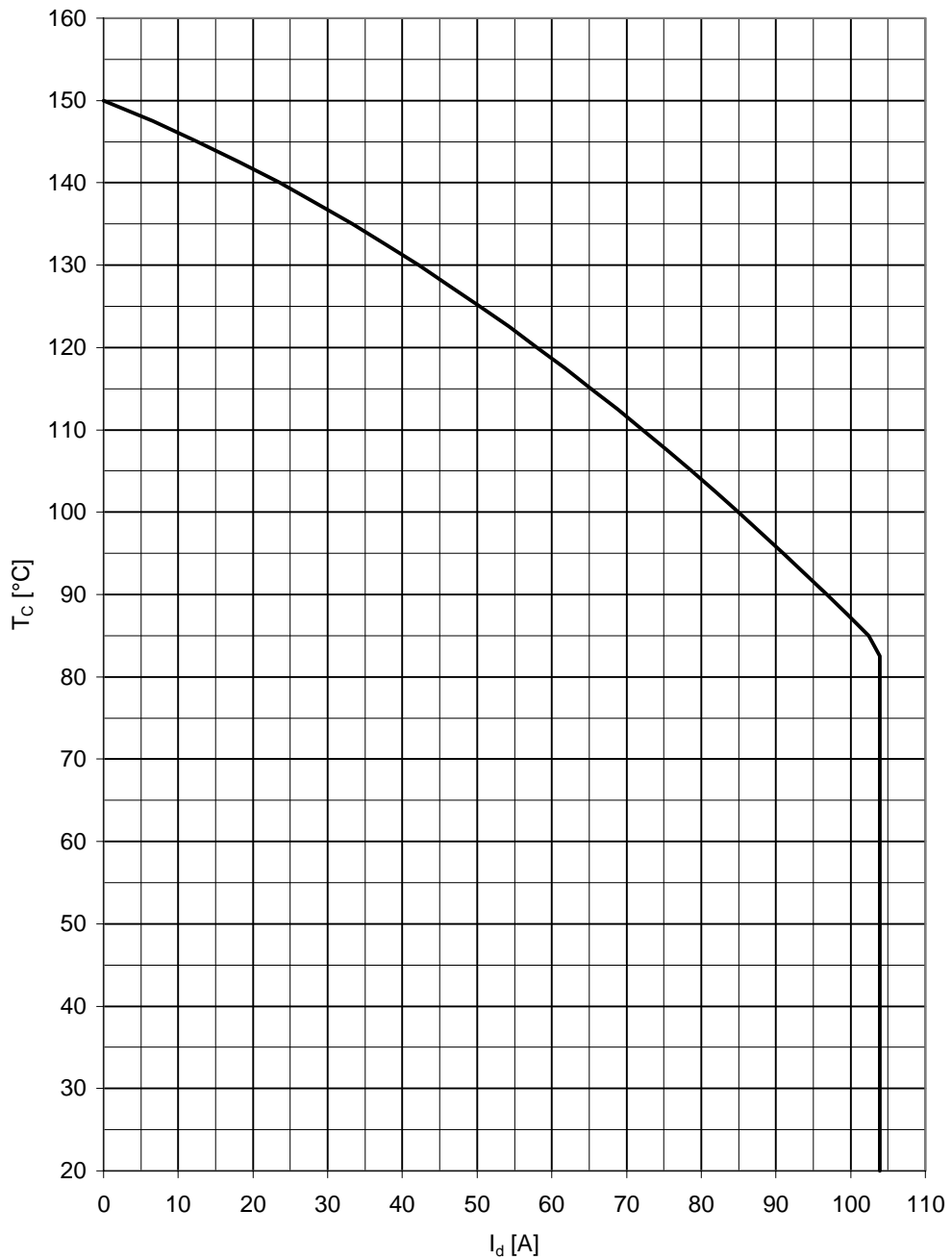

Höchstzulässige Gehäusetemperatur / Maximum allowable case temperature $T_c = f(I_d)$

Terms & Conditions of Usage

Attention

The present product data is exclusively subscribed to technically experienced staff. This Data Sheet is describing the specification of the products for which a warranty is granted exclusively pursuant the terms and conditions of the supply agreement. There will be no guarantee of any kind for the product and its specifications. Changes to the Data Sheet are reserved.

You and your technical departments will have to evaluate the suitability of the product for the intended application and the completeness of the product data with respect to such application. Should you require product information in excess of the data given in the Data Sheet, please contact your local Sales Office via "www.eupec.com / sales & contact".

Warning

Due to technical requirements the products may contain dangerous substances. For information on the types in question please contact your local Sales Office via "www.eupec.com / sales & contact".