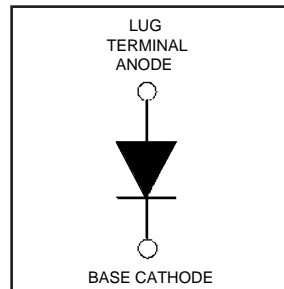


# HFA70NH60

Ultrafast, Soft Recovery Diode

## Features

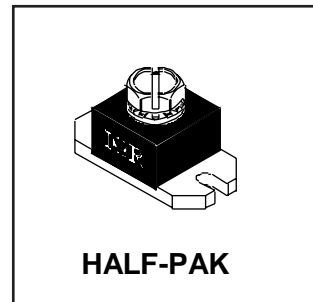
- Reduced RFI and EMI
- Reduced Snubbing
- Extensive Characterization of Recovery Parameters



$V_R = 600V$
$V_F(\text{typ.})^{\text{①}} = 1.2V$
$I_{F(AV)} = 70A$
$Q_{rr}(\text{typ.}) = 340nC$
$I_{RRM}(\text{typ.}) = 8.5A$
$t_{rr}(\text{typ.}) = 33ns$
$di_{(rec)M}/dt(\text{typ.})^{\text{①}} = 220A/\mu s$

## Description

HEXFRED™ diodes are optimized to reduce losses and EMI/RFI in high frequency power conditioning systems. An extensive characterization of the recovery behavior for different values of current, temperature and di/dt simplifies the calculations of losses in the operating conditions. The softness of the recovery eliminates the need for a snubber in most applications. These devices are ideally suited for power converters, motors drives and other applications where switching losses are significant portion of the total losses.



## Absolute Maximum Ratings (per Leg)

	Parameter	Max.	Units
$V_R$	Cathode-to-Anode Voltage	600	V
$I_F @ T_C = 25^\circ C$	Continuous Forward Current	126	A
$I_F @ T_C = 100^\circ C$	Continuous Forward Current	63	
$I_{FSM}$	Single Pulse Forward Current ①	400	
$E_{AS}$	Non-Repetitive Avalanche Energy ②	220	$\mu J$
$P_D @ T_C = 25^\circ C$	Maximum Power Dissipation	310	W
$P_D @ T_C = 100^\circ C$	Maximum Power Dissipation	125	
$T_J$	Operating Junction and	-55 to +150	$^\circ C$
$T_{STG}$	Storage Temperature Range		

## Thermal - Mechanical Characteristics

	Parameter	Min.	Typ.	Max.	Units
$R_{thJC}$	Junction-to-Case	—	—	0.4	$^\circ C/W$
$R_{thCS}$	Case-to-Sink, Flat, Greased Surface	—	0.15	—	K/W
Wt	Weight	—	26 (0.9)	—	g (oz)
	Mounting Torque ④	15 (1.7)	—	25 (2.8)	lbf•in
	Terminal Torque	30 (3.4)	—	40 (4.6)	(N•m)
	Vertical Pull	—	—	35	lbf•in
	2 inch Lever Pull	—	—	35	

**Note:** ① Limited by junction temperature  
 ②  $L = 100\mu H$ , duty cycle limited by max  $T_J$   
 ③  $125^\circ C$

④ Mounting surface must be smooth, flat, free of burrs or other protrusions. Apply a thin even film of thermal grease to mounting surface. Gradually tighten each mounting bolt in 5-10 lbf•in steps until desired or maximum torque limits are reached. Module

# HFA70NH60

PD -2.457 rev. B 02/99

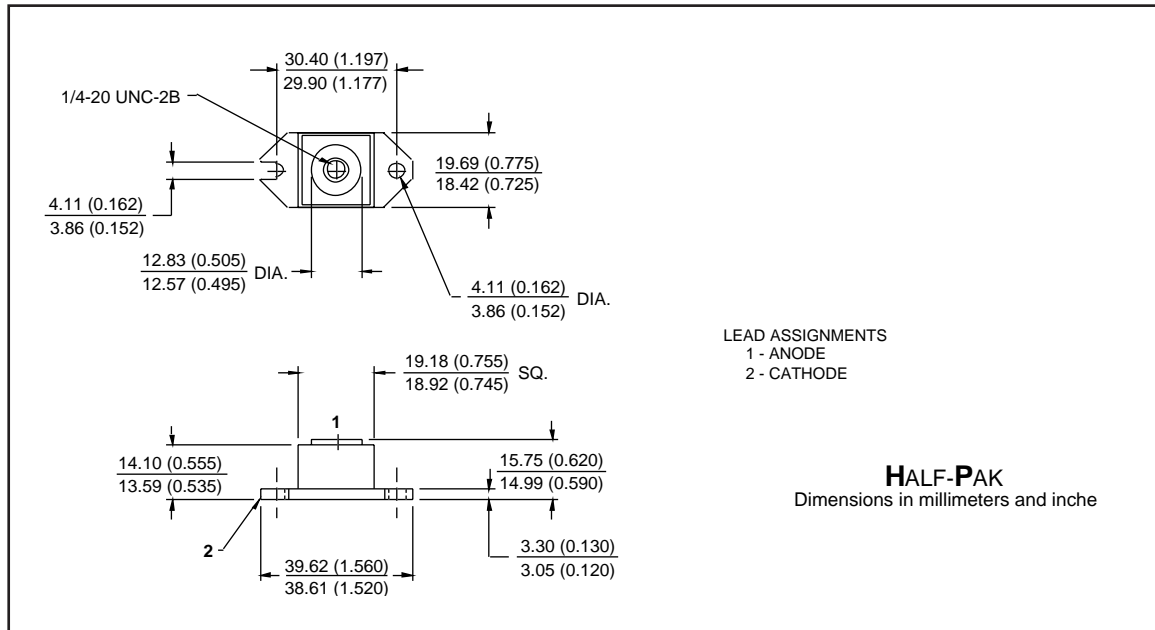
International  
IOR Rectifier

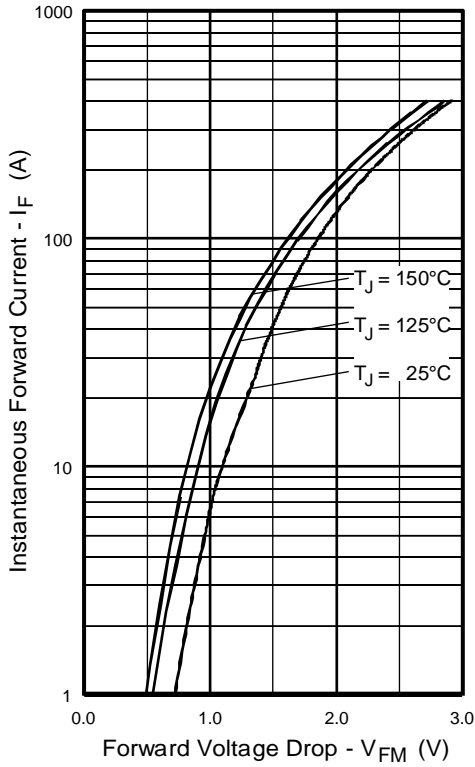
## Electrical Characteristics (per Leg) @ $T_J = 25^\circ\text{C}$ (unless otherwise specified)

Parameter	Min.	Typ.	Max.	Units	Test Conditions
$V_{BR}$ Cathode Anode Breakdown Voltage	600	—	—	V	$I_R = 100\mu\text{A}$
$V_{FM}$ Max Forward Voltage See Fig. 1	—	1.3	1.5	V	$I_F = 70\text{A}$
	—	1.5	1.7		$I_F = 140\text{A}$
	—	1.2	1.4		$I_F = 70\text{A}, T_J = 125^\circ\text{C}$
$I_{RM}$ Max Reverse Leakage Current See Fig. 2	—	4.0	20	$\mu\text{A}$	$V_R = V_R$ Rated
	—	1.0	4.0	$\text{mA}$	$T_J = 125^\circ\text{C}, V_R = 480\text{V}$
$C_T$ Junction Capacitance See Fig. 3	—	140	250	$\text{pF}$	$V_R = 200\text{V}$
$L_S$ Series Inductance	—	7.0	—	$\text{nH}$	From top of terminal hole to mounting plane

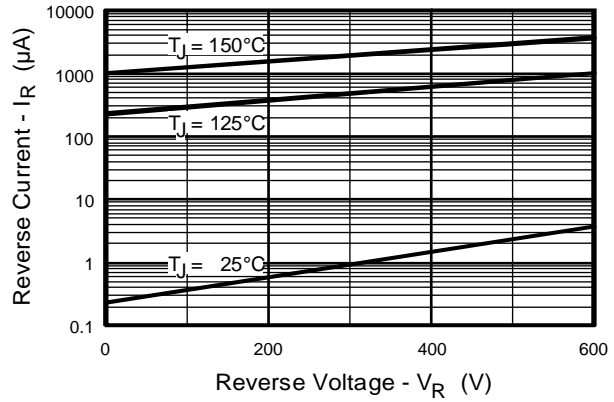
## Dynamic Recovery Characteristics (per Leg) @ $T_J = 25^\circ\text{C}$ (unless otherwise specified)

Parameter	Min.	Typ.	Max.	Units	Test Conditions
$t_{rr}$ Reverse Recovery Time	—	33	—	ns	$I_F = 1.0\text{A}, di_f/dt = 200\text{A}/\mu\text{s}, V_R = 30\text{V}$ $T_J = 25^\circ\text{C}$
$t_{rr1}$ See Fig. 5	—	80	120		
$t_{rr2}$	—	140	220		
$I_{RRM1}$ Peak Recovery Current	—	8.5	15	A	$T_J = 25^\circ\text{C}$ $T_J = 125^\circ\text{C}$
$I_{RRM2}$ See Fig. 6	—	14	25		
$Q_{rr1}$ Reverse Recovery Charge	—	340	900	nC	$T_J = 25^\circ\text{C}$ $T_J = 125^\circ\text{C}$
$Q_{rr2}$ See Fig. 7	—	980	2300		
$di_{(rec)M}/dt1$ Peak Rate of Fall of Recovery Current	—	300	—	$\text{A}/\mu\text{s}$	$T_J = 25^\circ\text{C}$ $T_J = 125^\circ\text{C}$
$di_{(rec)M}/dt2$ During $t_b$ See Fig. 8	—	220	—		

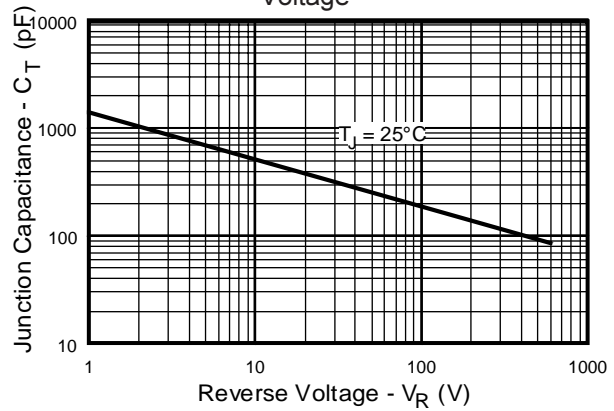




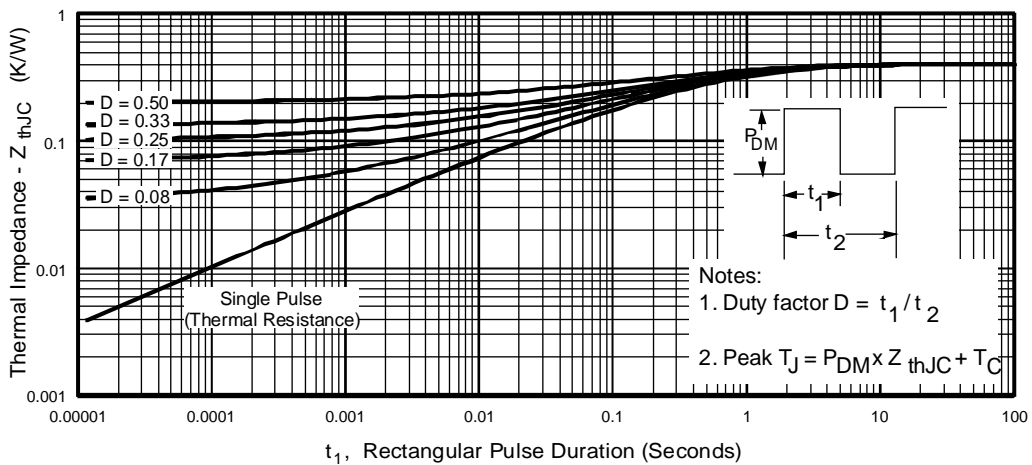
**Fig. 1 - Maximum Forward Voltage Drop vs. Instantaneous Forward Current**



**Fig. 2 - Typical Reverse Current vs. Reverse Voltage**



**Fig. 3 - Typical Junction Capacitance vs. Reverse Voltage**

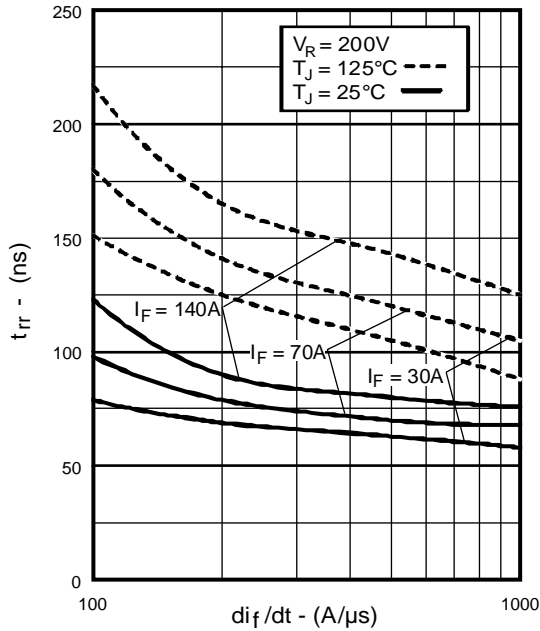


**Fig. 4 - Maximum Thermal Impedance  $Z_{thJC}$  Characteristics**

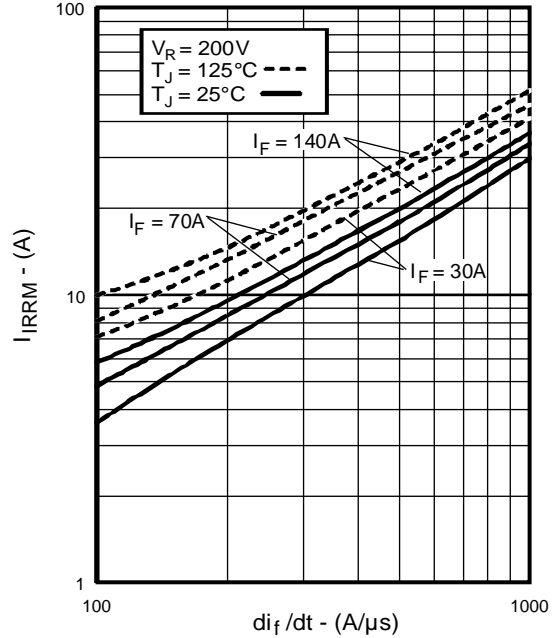
# HFA70NH60

PD -2.457 rev. B 02/99

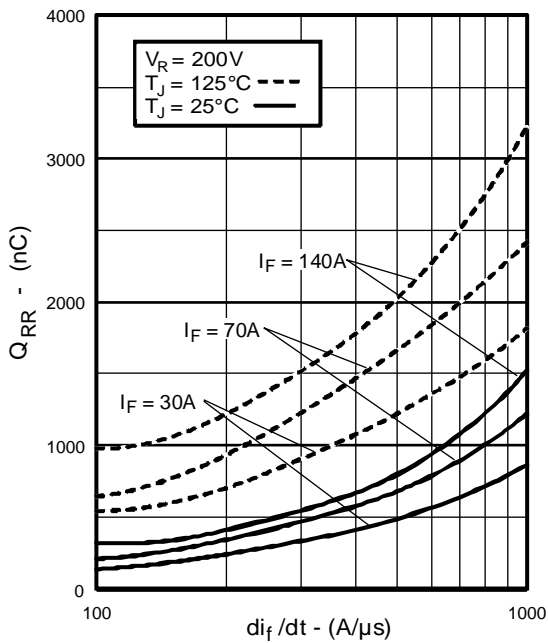
International  
**IOR** Rectifier



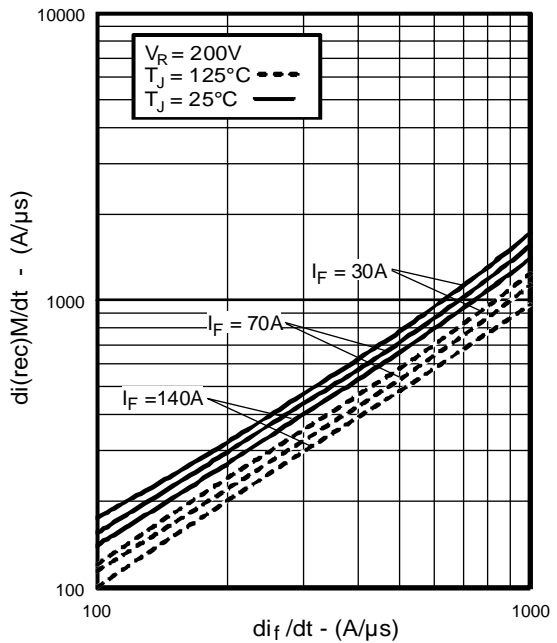
**Fig. 5** - Typical Reverse Recovery vs.  $di_f/dt$



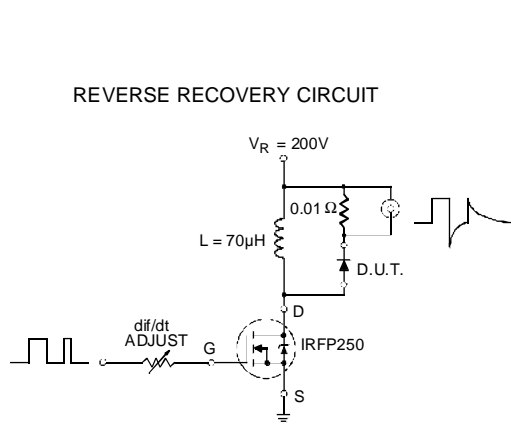
**Fig. 6** - Typical Recovery Current vs.  $di_f/dt$



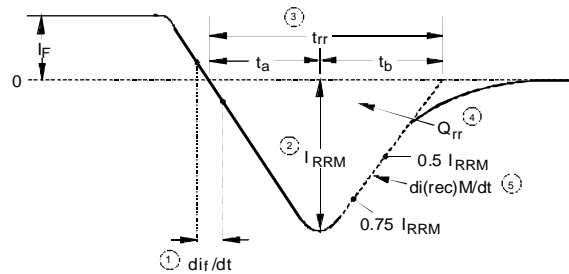
**Fig. 7** - Typical Stored Charge vs.  $di_f/dt$



**Fig. 8** - Typical  $di_{(rec)M}/dt$  vs.  $di_f/dt$



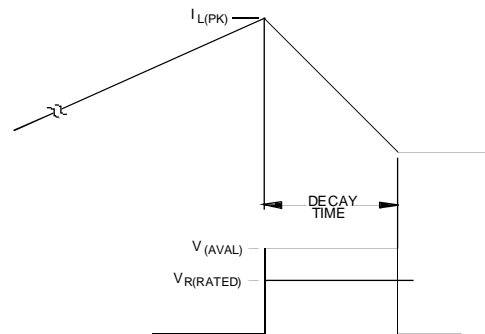
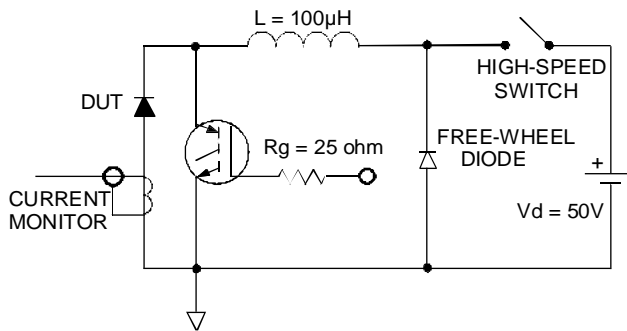
**Fig. 9 - Reverse Recovery Parameter Test Circuit**



1.  $di/dt$  - Rate of change of current through zero crossing
2.  $I_{RRM}$  - Peak reverse recovery current
3.  $t_{rr}$  - Reverse recovery time measured from zero crossing point of negative going  $I_F$  to point where a line passing through  $0.75 I_{RRM}$  and  $0.50 I_{RRM}$  extrapolated to zero current
4.  $Q_{rr}$  - Area under curve defined by  $t_{rr}$  and  $I_{RRM}$   

$$Q_{rr} = \frac{t_{rr} \times I_{RRM}}{2}$$
5.  $di_{(rec)}/dt$  - Peak rate of change of current during  $t_b$  portion of  $t_{rr}$

**Fig. 10 - Reverse Recovery Waveform and Definitions**



**Fig. 11 - Avalanche Test Circuit and Waveforms**