

# Thyristor Modules

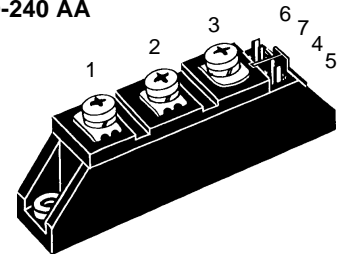
## Thyristor/Diode Modules

$$I_{TRMS} = 2x 180 A$$

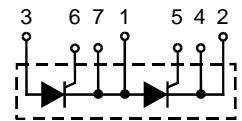
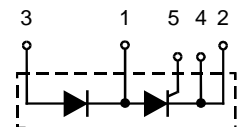
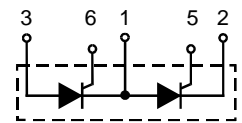
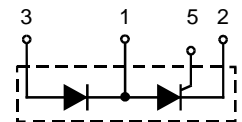
$$I_{TAVM} = 2x 115 A$$

$$V_{RRM} = 800-1800 V$$

$V_{RSM}$ $V_{DSM}$	$V_{RRM}$ $V_{DRM}$	Type	
V	V	Version 1 B	Version 8 B
900	800	MCC 72-08io1 B	--
1300	1200	MCC 72-12io1 B	MCD 72-12io1B
1500	1400	MCC 72-14io1 B	--
1700	1600	MCC 72-16io1 B	MCD 72-16io1B
1900	1800	MCC 72-18io1 B	--
		MCC 72-08io8 B	MCD 72-08io8 B
		MCC 72-12io8 B	MCD 72-12io8 B
		MCC 72-14io8 B	MCD 72-14io8 B
		MCC 72-16io8 B	MCD 72-16io8 B
		MCC 72-18io8 B	MCD 72-18io8 B

**TO-240 AA**


Symbol	Test Conditions	Maximum Ratings		
$I_{TRMS}, I_{FRMS}$ $I_{TAVM}, I_{FAVM}$	$T_{VJ} = T_{VJM}$ $T_C = 63^\circ C; 180^\circ$ sine $T_C = 85^\circ C; 180^\circ$ sine	180 115 85	A A A	
$I_{TSM}, I_{FSM}$	$T_{VJ} = 45^\circ C;$ $V_R = 0$ $t = 10$ ms (50 Hz), sine $t = 8.3$ ms (60 Hz), sine	1700 1800	A A	
	$T_{VJ} = T_{VJM}$ $V_R = 0$ $t = 10$ ms (50 Hz), sine $t = 8.3$ ms (60 Hz), sine	1540 1640	A A	
$\int i^2 dt$	$T_{VJ} = 45^\circ C$ $V_R = 0$ $t = 10$ ms (50 Hz), sine $t = 8.3$ ms (60 Hz), sine	14 450 13 500	A <sup>2</sup> s A <sup>2</sup> s	
	$T_{VJ} = T_{VJM}$ $V_R = 0$ $t = 10$ ms (50 Hz), sine $t = 8.3$ ms (60 Hz), sine	11 850 11 300	A <sup>2</sup> s A <sup>2</sup> s	
$(di/dt)_{cr}$	$T_{VJ} = T_{VJM}$ $f = 50$ Hz, $t_p = 200$ $\mu$ s $V_D = 2/3 V_{DRM}$ $I_G = 0.45$ A $di_G/dt = 0.45$ A/ $\mu$ s	repetitive, $I_T = 250$ A non repetitive, $I_T = I_{TAVM}$	150 500	A/ $\mu$ s A/ $\mu$ s
$(dv/dt)_{cr}$	$T_{VJ} = T_{VJM};$ $R_{GK} = \infty;$ method 1 (linear voltage rise)	$V_{DR} = 2/3 V_{DRM}$	1000	V/ $\mu$ s
$P_{GM}$	$T_{VJ} = T_{VJM}$ $I_T = I_{TAVM}$	$t_p = 30$ $\mu$ s $t_p = 300$ $\mu$ s	10 5	W W
$P_{GAV}$			0.5	W
$V_{RGM}$			10	V
$T_{VJ}$			-40...+125	$^\circ C$
$T_{VJM}$			125	$^\circ C$
$T_{stg}$			-40...+125	$^\circ C$
$V_{ISOL}$	50/60 Hz, RMS $I_{ISOL} \leq 1$ mA	$t = 1$ min $t = 1$ s	3000 3600	V~ V~
$M_d$	Mounting torque (M5) Terminal connection torque (M5)		2.5-4.0/22-35 2.5-4.0/22-35	Nm/lb.in. Nm/lb.in.
Weight	Typical including screws		90	g

**MCC**  
**Version 1 B**

**MCD**  
**Version 1 B**

**MCC**  
**Version 8 B**

**MCD**  
**Version 8 B**


### Features

- International standard package, JEDEC TO-240 AA
- Direct copper bonded Al<sub>2</sub>O<sub>3</sub> -ceramic base plate
- Planar passivated chips
- Isolation voltage 3600 V~
- UL registered, E 72873
- Gate-cathode twin pins for version 1B

### Applications

- DC motor control
- Softstart AC motor controller
- Light, heat and temperature control

### Advantages

- Space and weight savings
- Simple mounting with two screws
- Improved temperature and power cycling
- Reduced protection circuits

Data according to IEC 60747 and refer to a single thyristor/diode unless otherwise stated. IXYS reserves the right to change limits, test conditions and dimensions

Symbol	Test Conditions	Characteristic Values
$I_{RRM}, I_{DRM}$	$T_{VJ} = T_{VJM}; V_R = V_{RRM}; V_D = V_{DRM}$	5 mA
$V_T, V_F$	$I_T, I_F = 300 \text{ A}; T_{VJ} = 25^\circ\text{C}$	1.74 V
$V_{T0}$	For power-loss calculations only ( $T_{VJ} = 125^\circ\text{C}$ )	0.85 V
$r_T$		3.2 mΩ
$V_{GT}$	$V_D = 6 \text{ V}; T_{VJ} = 25^\circ\text{C}$	2.5 V
	$T_{VJ} = -40^\circ\text{C}$	2.6 V
$I_{GT}$	$V_D = 6 \text{ V}; T_{VJ} = 25^\circ\text{C}$	150 mA
	$T_{VJ} = -40^\circ\text{C}$	200 mA
$V_{GD}$	$T_{VJ} = T_{VJM}; V_D = 2/3 V_{DRM}$	0.2 V
$I_{GD}$		10 mA
$I_L$	$T_{VJ} = 25^\circ\text{C}; t_p = 10 \mu\text{s}; V_D = 6 \text{ V}$ $I_G = 0.45 \text{ A}; di_G/dt = 0.45 \text{ A}/\mu\text{s}$	450 mA
$I_H$	$T_{VJ} = 25^\circ\text{C}; V_D = 6 \text{ V}; R_{GK} = \infty$	200 mA
$t_{gd}$	$T_{VJ} = 25^\circ\text{C}; V_D = 1/2 V_{DRM}$ $I_G = 0.45 \text{ A}; di_G/dt = 0.45 \text{ A}/\mu\text{s}$	2 μs
$t_q$	$T_{VJ} = T_{VJM}; I_T = 150 \text{ A}, t_p = 200 \mu\text{s}; -di/dt = 10 \text{ A}/\mu\text{s}$ typ. $V_R = 100 \text{ V}; dv/dt = 20 \text{ V}/\mu\text{s}; V_D = 2/3 V_{DRM}$	185 μs
$Q_S$	$T_{VJ} = T_{VJM}; I_T, I_F = 50 \text{ A}, -di/dt = 6 \text{ A}/\mu\text{s}$	170 μC
$I_{RM}$		45 A
$R_{thJC}$	per thyristor/diode; DC current per module	0.3 K/W
$R_{thJK}$	per thyristor/diode; DC current per module	0.15 K/W
	other values see Fig. 8/9	0.5 K/W
		0.25 K/W
$d_s$	Creepage distance on surface	12.7 mm
$d_A$	Strike distance through air	9.6 mm
$a$	Maximum allowable acceleration	50 m/s <sup>2</sup>

Optional accessories for module-type MCC 72 version 1 B

Keyed gate/cathode twin plugs with wire length = 350 mm, gate = yellow, cathode = red

Type ZY 200L (L = Left for pin pair 4/5) } UL 758, style 1385,  
Type ZY 200R (R = right for pin pair 6/7) } CSA class 5851, guide 460-1-1

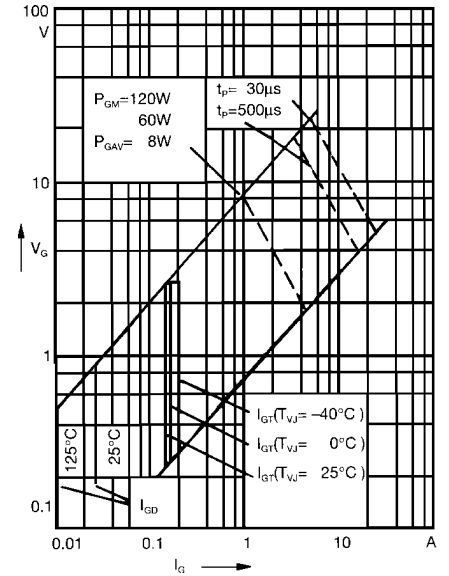


Fig. 1 Gate trigger characteristics

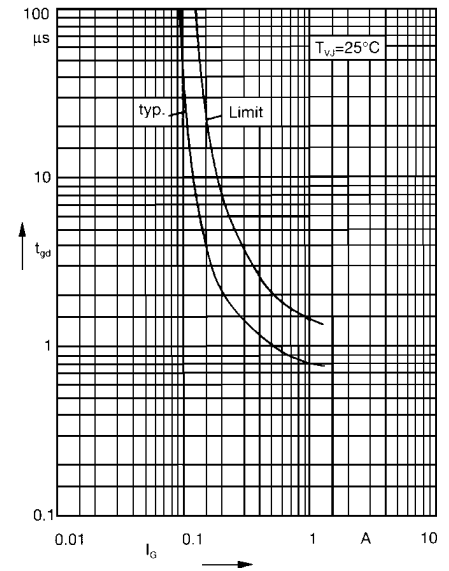
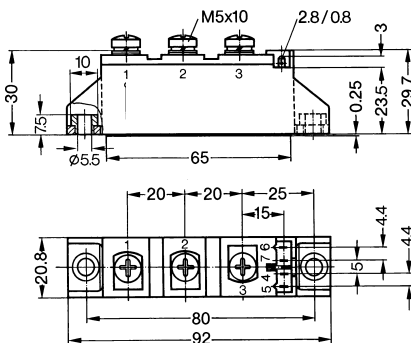


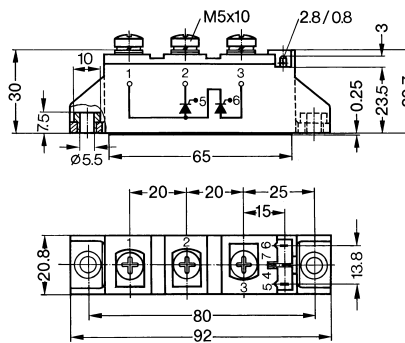
Fig. 2 Gate trigger delay time

Dimensions in mm (1 mm = 0.0394")

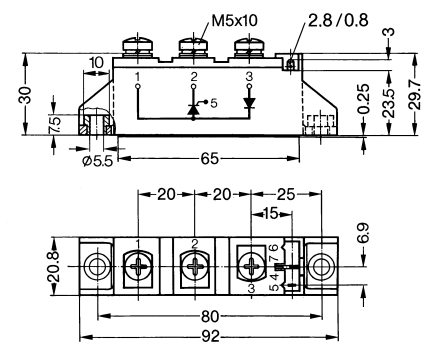
### MCC / MCD Version 1 B

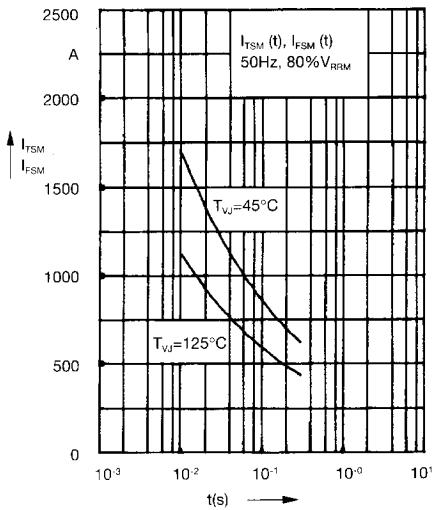


### MCC Version 8 B

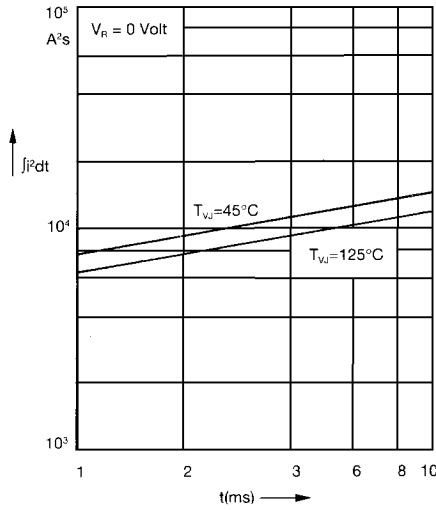


### MCD Version 8 B

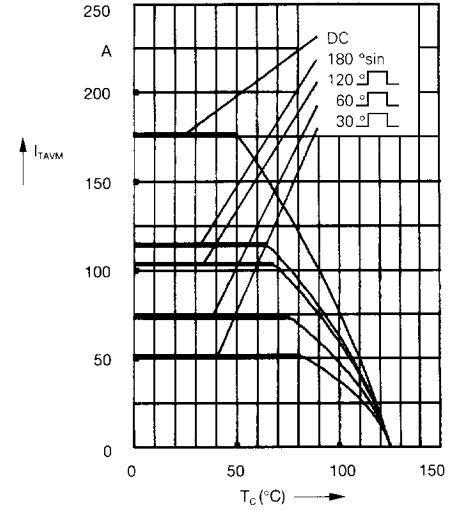




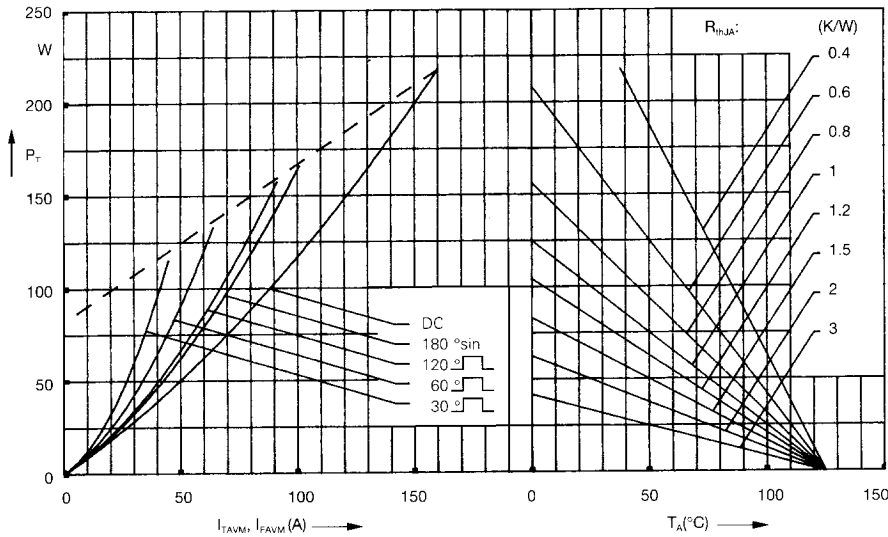
**Fig. 3 Surge overload current**  
 $I_{TSM}$ ,  $I_{FSM}$ : Crest value,  $t$ : duration



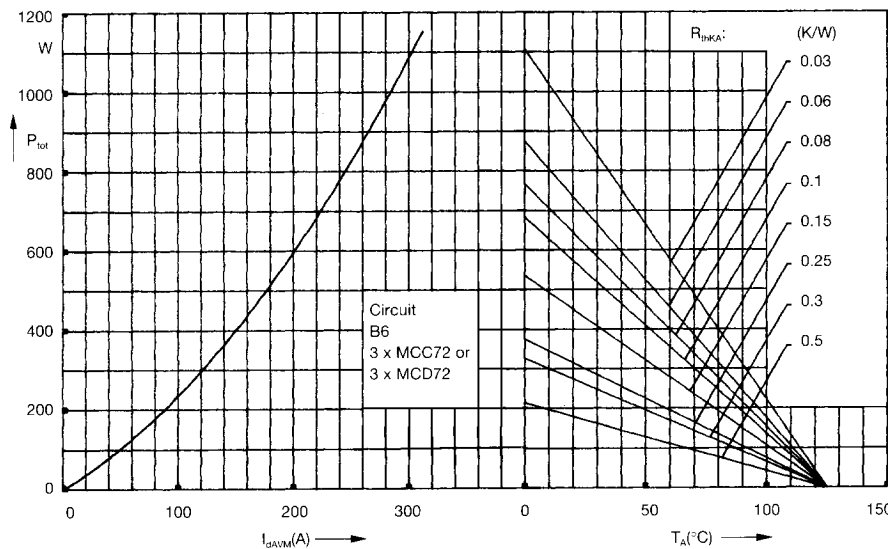
**Fig. 4  $\int i^2 dt$  versus time (1-10 ms)**



**Fig. 4a Maximum forward current at case temperature**



**Fig. 5 Power dissipation versus on-state current and ambient temperature (per thyristor or diode)**



**Fig. 6 Three phase rectifier bridge: Power dissipation versus direct output current and ambient temperature**

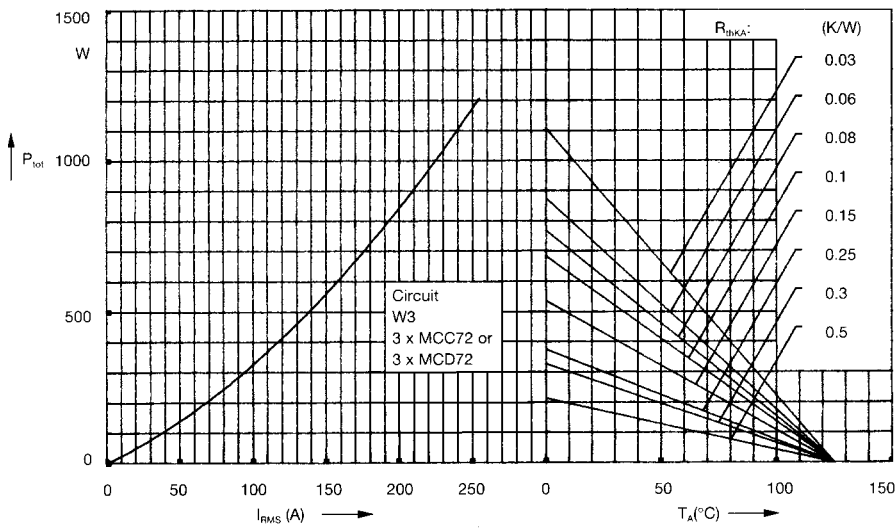


Fig. 7 Three phase AC-controller: Power dissipation versus RMS output current and ambient temperature

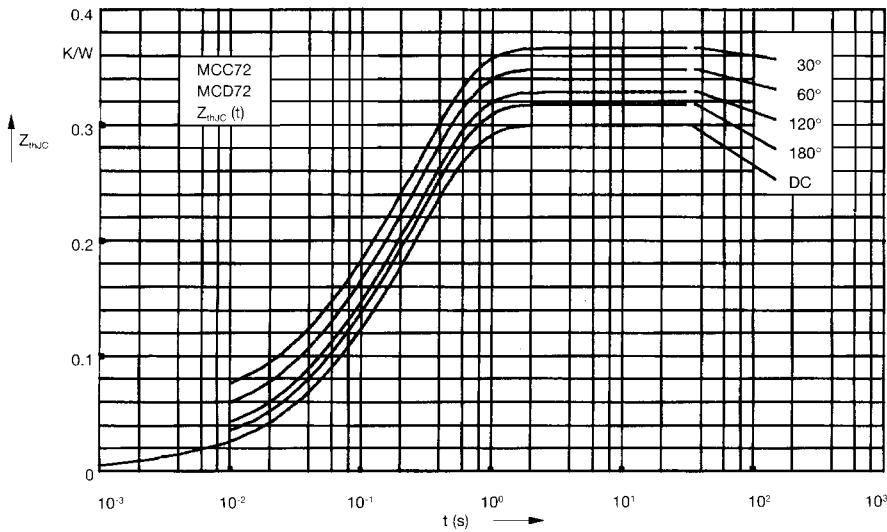


Fig. 8 Transient thermal impedance junction to case (per thyristor or diode)

$R_{thJC}$  for various conduction angles d:

d	$R_{thJC}$ (K/W)
DC	0.3
180°	0.31
120°	0.33
60°	0.35
30°	0.37

Constants for  $Z_{thJC}$  calculation:

i	$R_{thi}$ (K/W)	$t_i$ (s)
1	0.008	0.0019
2	0.054	0.047
3	0.238	0.3

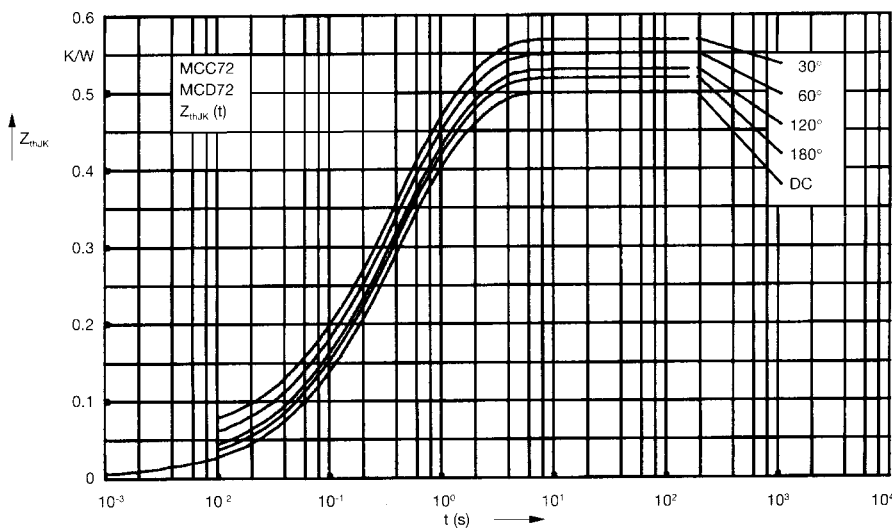


Fig. 9 Transient thermal impedance junction to heatsink (per thyristor or diode)

$R_{thJK}$  for various conduction angles d:

d	$R_{thJK}$ (K/W)
DC	0.5
180°	0.51
120°	0.53
60°	0.55
30°	0.57

Constants for  $Z_{thJK}$  calculation:

i	$R_{thi}$ (K/W)	$t_i$ (s)
1	0.008	0.0019
2	0.054	0.047
3	0.238	0.3
4	0.2	1.25