

## DIODE(NON-ISOLATED TYPE)

# MDF(R)100A

TOP



MDF (R)100A is a diode with flat mounting base which is designed for use in various rectifier applications.

- $I_{F(AV)}=100A$ ,  $V_{RRM}=500V$
- Easy Construction with Anode (F) Type and Cathode (R) type.
- High reliability by glass passivation

### (Applications)

Various Rectifiers  
Welding Power Supply

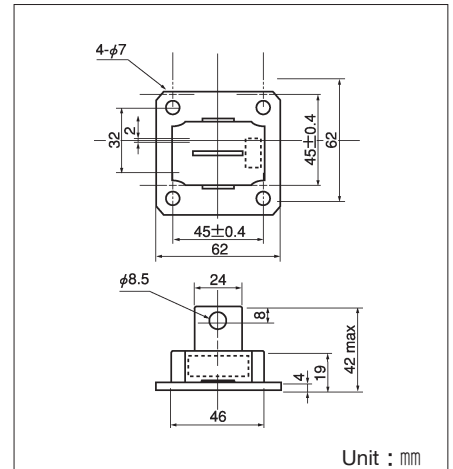
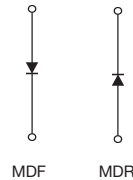

### Maximum Ratings

( $T_j=25^{\circ}C$ )

Symbol	Item	Ratings			Unit
		MDF(R)100A30	MDF(R)100A40	MDF(R)100A50	
$V_{RRM}$	Repetitive Peak Reverse Voltage	300	400	500	V
$V_{RSM}$	Non-Repetitive Peak Reverse Voltage	360	480	600	V
$V_R(DC)$	D.C. Reverse Voltage	240	320	400	V

Symbol	Item	Conditions	Ratings	Unit	
$I_{F(AV)}$	Average Forward Current	Single phase, half wave, $180^{\circ}$ conduction, $T_c : 109^{\circ}C$	100	A	
$I_{F(RMS)}$	R.M.S. Forward Current	Single phase, half wave, $180^{\circ}$ conduction, $T_c : 109^{\circ}C$	157	A	
$I_{FSM}$	Surge Forward Current	$1/2$ cycle, 50Hz/60Hz, peak value, non-repetitive	1800/2000	A	
$I^2t$	$I^2t$	Value for one cycle of surge current	16700	$A^2S$	
$T_j$	Junction Temperature		$-30 \sim +150$	$^{\circ}C$	
$T_{stg}$	Storage Temperature		$-30 \sim +125$	$^{\circ}C$	
	Mounting Torque	Mounting (M6)	Recommended Value 2.5~3.9 (25~40)	4.7 (48)	N·m (kgf·cm)
		Terminal (M8)	Recommended Value 8.8~10 (90~105)	11 (115)	
	Mass			170	g

### Electrical Characteristics

Symbol	Item	Conditions	Ratings	Unit
$I_{RRM}$	Repetitive Peak Reverse Current, max.	at $V_{DRM}$ , single phase, half wave, $T_j=150^{\circ}C$	6	mA
$V_{FM}$	Forward Voltage Drop, max.	Foward current 310A, $T_j=25^{\circ}C$ , Inst. measurement	1.15	V
$R_{th(j-c)}$	Thermal Impedance, max.	Junction to case	0.35	$^{\circ}C/W$

**Maximum Forward Characteristics**

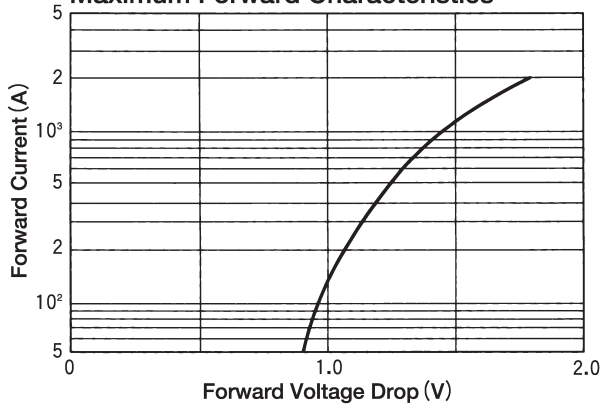

**Average Forward Current vs. Power Dissipation**

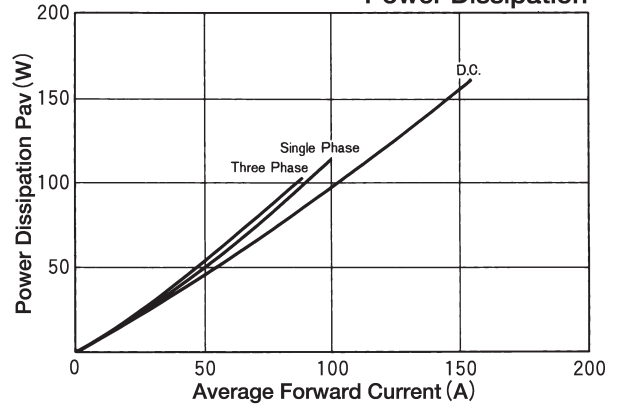

**Average Forward Current vs. Allowable Case Temperature**

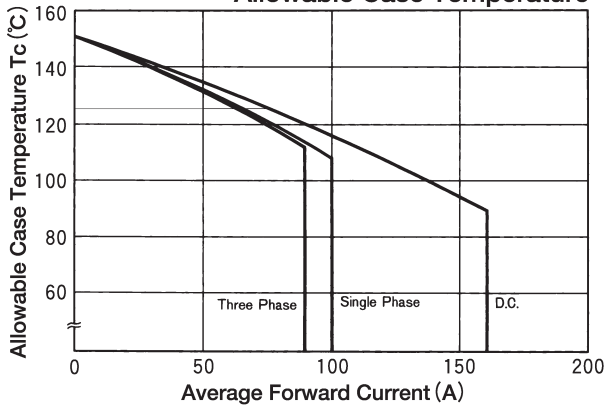

**Cycle Surge Forward Current Rating (Non-Repetitive)**

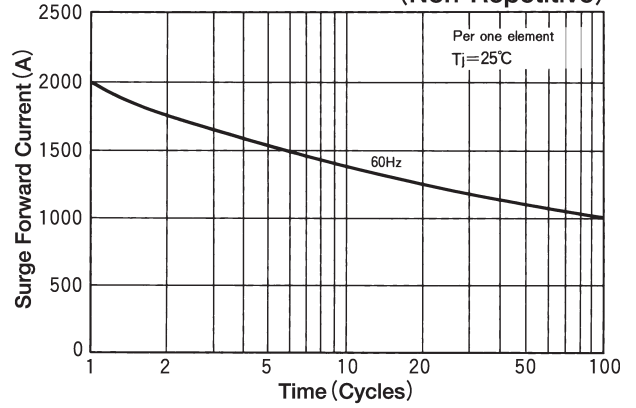

**Transient Thermal Impedance**

