

Schematic

Description:

The Powerex Common Cathode Series Modules utilize field proven super fast H-series FWD chips necessary for fast switching applications. The terminal design of the module allows for parallel operation of the internal diodes, providing the user with either dual common cathode connected diodes, or a single diode rated at twice the current of the dual (by connecting pins 1 & 3 together). Two (2) terminal heights are available (30 and 36mm) to facilitate matching existing power modules, making bussbar connections fast and economical. As with all Powerex modules, the series are electrically isolated for easy mounting with other components on common heatsinks.

Features:

Powerex FLEX-TERM terminals

Parallel Diodes for up to 600A

Isolated Mounting 2500Vacrms

H-Series Planar Chips

Applications:

Inverters

Choppers

Welding Power Supplies

High Frequency Rectifiers

Switching Power Supplies

Free Wheeling Diode

Regenerative Braking



Preliminary Common Cathode Series

Powerex Inc., 200 Hillis St., Youngwood 15697 (724)925-7272

Dual Fast Diode Series

Absolute Max. Ratings											
Characteristics	Symbol	QRC0610 T30	QRC0620 T30	QRC0630 T30	QRC1210 T30	QRC1220 T30	QRC1230 T30	QRC1410 T30	QRC1420 T30	QRC1430 T30	Units
Peak Reverse Blocking Voltage	V_{RRM}	600	600	600	1200	1200	1200	1400	1400	1400	Volts
DC Current (each diode)	I_F	100	200	300	100	200	300	100	200	300	Amps
Surge Current	I_{FSM}	200	400	600	200	400	600	200	400	600	Amps
Junction Temperature	T_j	-40 to 150	-40 to 150	-40 to 150	-40 to 150	-40 to 150	-40 to 150	-40 to 150	-40 to 150	-40 to 150	°C
Storage Temperature	T_{STG}	-40 to 150	-40 to 150	-40 to 150	-40 to 150	-40 to 150	-40 to 150	-40 to 150	-40 to 150	-40 to 150	°C
Maximum Mounting Torque M6 Mounting Screw		20-30	20 - 30	20 - 30	20 - 30	20 - 30	20 - 30	20 - 30	20 - 30	20 - 30	kg-cm
Maximum Terminal Torque M6 Terminal Screw		20-30	20 - 30	20 - 30	20 - 30	20 - 30	20 - 30	20 - 30	20 - 30	20 - 30	kg-cm
Module Weight		200	200	200	200	200	200	200	200	200	gm
V Isolation	V_{RMS}	2500	2500	2500	2500	2500	2500	2500	2500	2500	Volts

600 Volt / 100 Amp Devices				
Electrical and Thermal Characteristics, $T_j = 25^\circ\text{C}$ unless otherwise specified				
Characteristics	Symbol	Test Conditions	QRC0610T30	Units
Reverse Leakage Current, Peak	I_{RRM}	$T_j=150^\circ\text{C}$, $V_{RRM} = \text{Rated}$	1.0 max.	mA
Peak On-State Voltage	V_{FM}	$I_{FM}=100\text{A}$	2.8 max.	Volts
Reverse Recovery Time	t_{rr}	$I_{FM}=100\text{A}$, $di_{FM}/dt=-200\text{A}/\mu\text{S}$	110	nS
Reverse Recovery Charge	Q_{rr}	$I_{FM}=100\text{A}$, $di_{FM}/dt=-200\text{A}/\mu\text{S}$	0.54	uC
Thermal Maximums				
Thermal Resistance Junction-to-Case	R(J-C)	Per Module	.35 max.	°C/Watt
Thermal Resistance Case-to-Sink	R(C-S)	Per Module	.04 max.	°C/watt
600 Volt / 200 Amp Devices				
Electrical and Thermal Characteristics, $T_j = 25^\circ\text{C}$ unless otherwise specified				
Characteristics	Symbol	Test Conditions	QRC0620T30	Units
Reverse Leakage Current, Peak	I_{RRM}	$T_j=150^\circ\text{C}$, $V_{RRM} = \text{Rated}$	1.0 max.	mA
Peak On-State Voltage	V_{FM}	$I_{FM}=200\text{A}$	2.8 max.	Volts
Reverse Recovery Time	t_{rr}	$I_{FM}=200\text{A}$, $di_{FM}/dt=-400\text{A}/\mu\text{S}$	110	nS
Reverse Recovery Charge	Q_{rr}	$I_{FM}=200\text{A}$, $di_{FM}/dt=-400\text{A}/\mu\text{S}$	1.08	uC
Thermal Maximums				
Thermal Resistance Junction-to-Case	R(J-C)	Per Module	.18 max.	°C/Watt
Thermal Resistance Case-to-Sink	R(C-S)	Per Module	.04 max.	°C/watt
600 Volt / 300 Amp Devices				
Electrical and Thermal Characteristics, $T_j = 25^\circ\text{C}$ unless otherwise specified				
Characteristics	Symbol	Test Conditions	QRC0630T30	Units
Reverse Leakage Current, Peak	I_{RRM}	$T_j=150^\circ\text{C}$, $V_{RRM} = \text{Rated}$	1.0 max.	mA
Peak On-State Voltage	V_{FM}	$I_{FM}=300\text{A}$	2.8 max.	Volts
Reverse Recovery Time	t_{rr}	$I_{FM}=300\text{A}$, $di_{FM}/dt=-600\text{A}/\mu\text{S}$	110	nS
Reverse Recovery Charge	Q_{rr}	$I_{FM}=300\text{A}$, $di_{FM}/dt=-600\text{A}/\mu\text{S}$	1.62	uC
Thermal Maximums				
Thermal Resistance Junction-to-Case	R(J-C)	Per Module	.12 max.	°C/Watt
Thermal Resistance Case-to-Sink	R(C-S)	Per Module	.04 max.	°C/Watt



Preliminary Common Cathode Series

Powerex Inc., 200 Hillis St., Youngwood 15697 (724)925-7272

Dual Fast Diode Series

1200 Volt / 100 Amp Devices				
Electrical and Thermal Characteristics, T _j = 25°C unless otherwise specified				
Characteristics	Symbol	Test Conditions	QRC1210T30	Units
Reverse Leakage Current, Peak	I _{RRM}	T _j =150°C, V _{RRM} = Rated	1.0 max.	mA
Peak On-State Voltage	V _{FM}	I _{FM} =100A	3.5 max.	Volts
Reverse Recovery Time	t _{rr}	I _{FM} =100A, di _{FM} /dt=-200A/uS	250	nS
Reverse Recovery Charge	Q _{rr}	I _{FM} =100A, di _{FM} /dt=-200A/uS	1.49	uC
Thermal Maximums				
Thermal Resistance Junction-to-Case	R(J-C)	Per Module	.18 max.	°C/Watt
Thermal Resistance Case-to-Sink	R(C-S)	Per Module	.04 max.	°C/Watt
1200 Volt / 200 Amp Devices				
Electrical and Thermal Characteristics, T _j = 25°C unless otherwise specified				
Characteristics	Symbol	Test Conditions	QRC1220T30	Units
Reverse Leakage Current, Peak	I _{RRM}	T _j =150°C, V _{RRM} = Rated	1.0 max.	mA
Peak On-State Voltage	V _{FM}	I _{FM} =200A	3.5 max	Volts
Reverse Recovery Time	t _{rr}	I _{FM} =200A, di _{FM} /dt=-400A/uS	250	nS
Reverse Recovery Charge	Q _{rr}	I _{FM} =200A, di _{FM} /dt=-400A/uS	2.97	uC
Thermal Maximums				
Thermal Resistance Junction-to-Case	R(J-C)	Per Module	.09 max.	°C/Watt
Thermal Resistance Case-to-Sink	R(C-S)	Per Module	.04 max.	°C/Watt
1200 Volt / 300 Amp Devices				
Electrical and Thermal Characteristics, T _j = 25°C unless otherwise specified				
Characteristics	Symbol	Test Conditions	QRC1230T30	Units
Reverse Leakage Current, Peak	I _{RRM}	T _j =150°C, V _{RRM} = Rated	1.0 max.	mA
Peak On-State Voltage	V _{FM}	I _{FM} =300A	3.5 max.	Volts
Reverse Recovery Time	t _{rr}	I _{FM} =300A, di _{FM} /dt=-600A/uS	250	nS
Reverse Recovery Charge	Q _{rr}	I _{FM} =300A, di _{FM} /dt=-600A/uS	4.46	uC
Thermal Maximums				
Thermal Resistance Junction-to-Case	R(J-C)	Per Module	.06 max.	°C/Watt
Thermal Resistance Case-to-Sink	R(C-S)	Per Module	.04 max.	°C/Watt



Preliminary Common Cathode Series

Powerex Inc., 200 Hillis St., Youngwood 15697 (724)925-7272

Dual Fast Diode Series

1400 Volt / 100 Amp Devices				
Electrical and Thermal Characteristics, Tj = 25°C unless otherwise specified				
Characteristics	Symbol	Test Conditions	QRC1410T30	Units
Reverse Leakage Current, Peak	I _{RRM}	T _j =150°C, V _{RRM} = Rated	1.0 max.	mA
Peak On-State Voltage	V _{FM}	I _{FM} =100A	3.8 max.	Volts
Reverse Recovery Time	t _{rr}	I _{FM} =100A, di _{FM} /dt=-200A/uS	300	nS
Reverse Recovery Charge	Q _{rr}	I _{FM} =100A, di _{FM} /dt=-200A/uS	2.0	uC
Thermal Maximums				
Thermal Resistance Junction-to-Case	R(J-C)	Per Module	.18 max.	°C/Watt
Thermal Resistance Case-to-Sink	R(C-S)	Per Module	.04 max.	°C/Watt
1400 Volt / 200 Amp Devices				
Electrical and Thermal Characteristics, Tj = 25°C unless otherwise specified				
Characteristics	Symbol	Test Conditions	QRC1420T30	Units
Reverse Leakage Current, Peak	I _{RRM}	T _j =150°C, V _{RRM} = Rated	1.0 max.	mA
Peak On-State Voltage	V _{FM}	I _{FM} =200A	3.8 max	Volts
Reverse Recovery Time	t _{rr}	I _{FM} =200A, di _{FM} /dt=-400A/uS	300	nS
Reverse Recovery Charge	Q _{rr}	I _{FM} =200A, di _{FM} /dt=-400A/uS	4.0	uC
Thermal Maximums				
Thermal Resistance Junction-to-Case	R(J-C)	Per Module	.09 max.	°C/Watt
Thermal Resistance Case-to-Sink	R(C-S)	Per Module	.04 max.	°C/Watt
1400 Volt / 300 Amp Devices				
Electrical and Thermal Characteristics, Tj = 25°C unless otherwise specified				
Characteristics	Symbol	Test Conditions	QRC1430T30	Units
Reverse Leakage Current, Peak	I _{RRM}	T _j =150°C, V _{RRM} = Rated	1.0 max.	mA
Peak On-State Voltage	V _{FM}	I _{FM} =300A	3.8 max.	Volts
Reverse Recovery Time	t _{rr}	I _{FM} =300A, di _{FM} /dt=-600A/uS	300	nS
Reverse Recovery Charge	Q _{rr}	I _{FM} =300A, di _{FM} /dt=-600A/uS	6.0	uC
Thermal Maximums				
Thermal Resistance Junction-to-Case	R(J-C)	Per Module	.06 max.	°C/Watt
Thermal Resistance Case-to-Sink	R(C-S)	Per Module	.04 max.	°C/Watt

Outline Drawing

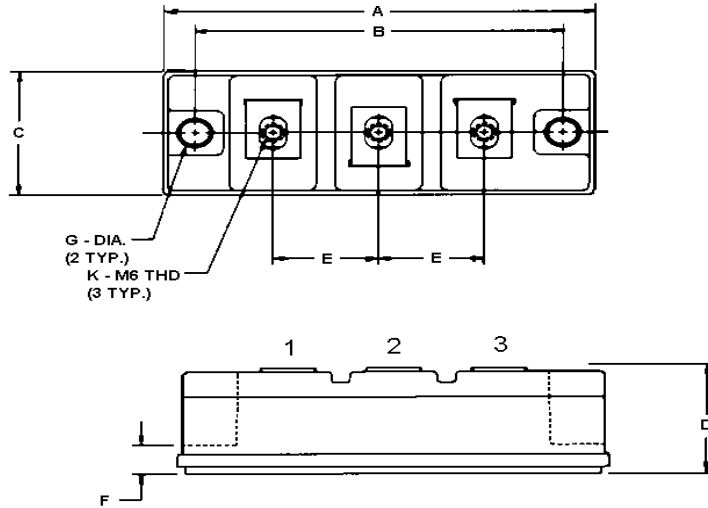

Dimensions	Inches		Millimeters	
	Min.	Max.	Min.	Max.
A	3.68	3.72	93.5	94.5
B	3.145	3.155	79.88	80.14
C	1.33	1.35	33.8	34.3
D (T36)	1.40	1.44	35.50	36.5
D* (T30)	1.16	1.20	29.5	30.5
E	.901	.911	22.88	23.14
F	.31	.33	7.9	8.4
Gϕ	.251	.261	6.38	6.63
K	-----	-----	M6 x 1.0	