

**Capsule Rectifier Diode**

T-01-23

Consists of a diffused silicon element mounted in an hermetic ceramic cold welded capsule. Available in industry standard and thin housings.

Ratings	Unless otherwise stated $T_j = 160^\circ\text{C}$	Maximum Limits						Units
		20	22	24	26	28	30	
$V_{RRM}$	Repetitive peak reverse voltage.	2000	2200	2400	2600	2800	3000	V
$V_{RSM}$	Non-repetitive peak reverse voltage.	2100	2300	2500	2700	2900	3100	V

$I_{F(AV)}$	Average forward current	Half sine wave	55°C heatsink temperature (double side cooled)	4310	A
			100°C heatsink temperature (single side cooled)	1900	A
$I_{F(RMS)}$	R.M.S forward current		25°C heatsink temperature, double side cooled	7875	A
$I_F$	Continuous forward current		25°C heatsink temperature, double side cooled	7060	A
$I_{FSM(1)}$	Peak one-cycle surge	10ms duration, 60% $V_{RRM}$ re-applied		55.0	KA
$I_{FSM(2)}$	Peak one-cycle surge	10ms duration, $V_R \leq 10$ volts		60.5	KA
$I^2 t_{(2)}$	Maximum permissible surge energy	10ms duration, $V_R \leq 10$ volts		$18.3 \times 10^6$	$A^2 s$
		3ms duration, $V_R \leq 10$ volts		$13.6 \times 10^6$	$A^2 s$
$T_j$	Operating temperature range			-55 to +160	$^\circ\text{C}$
$T_{stg}$	Storage temperature range			-55 to +160	$^\circ\text{C}$

Characteristics		Unless otherwise indicated $T_j = 160^\circ\text{C}$		
$V_{FM}$	Peak forward voltage	$I_F = 6000$ A	1.60	V
$V_O$	Forward conduction threshold voltage		0.80	V
$r$	Forward conduction slope resistance		0.133	$m\Omega$
$I_{RRM}$	Repetitive peak reverse current	At $V_{RRM}$	100.0	mA
$R_{th(j-hs)}$	Thermal resistance, junction to heat sink.	Double side cooled	0.011	$^\circ\text{C/W}$
		Single side cooled	0.022	$^\circ\text{C/W}$

**Ordering Information** (Please quote device code as explained below - 10 digits)

S	W	• •	• X C	2 0 C
Fixed type code	Voltage Code (see ratings)	CXC - Thick Housing DXC - Thin Housing	Fixed Type Code	

Typical code : SW24CXC20C, 2400  $V_{RRM}$

Details of a full range of capsule mounting clamps are available - ask for brochure.

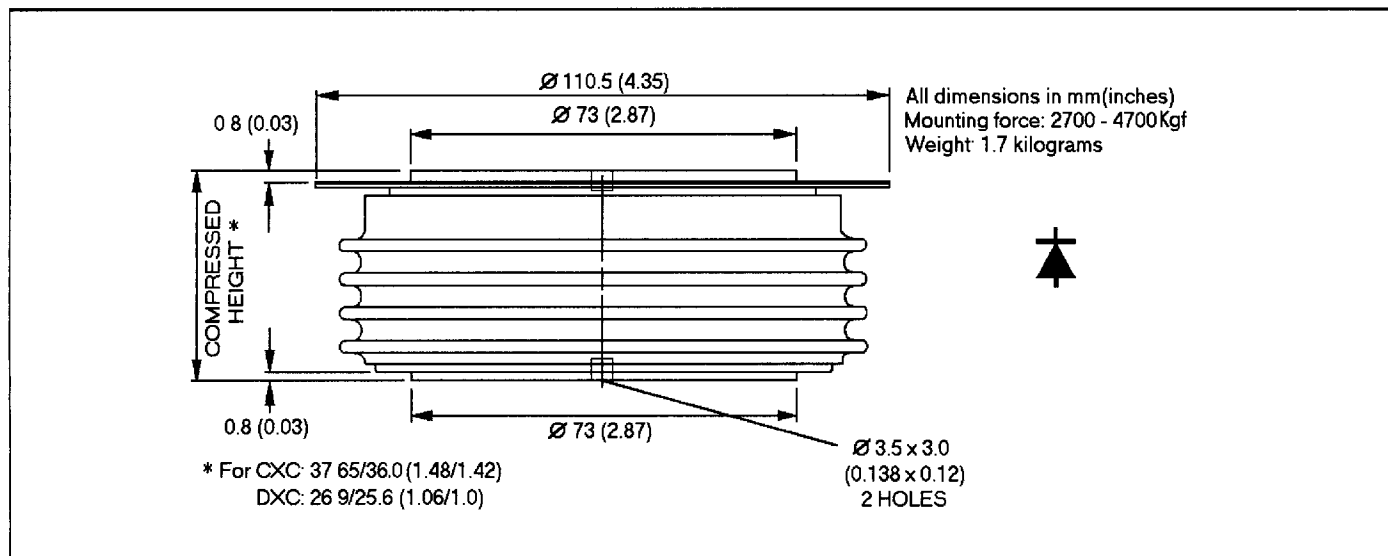

Figure 1. Dissipation/Sink Temperature v. Mean Forward Current.

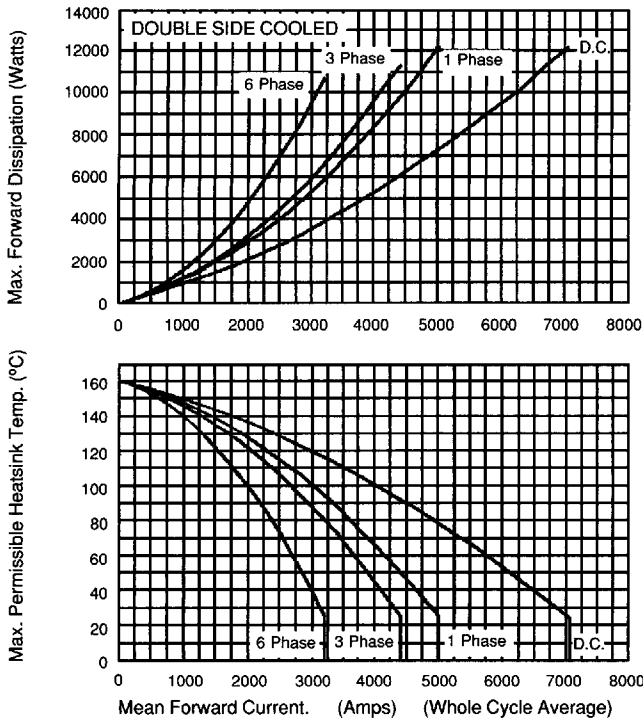

Figure 2. Dissipation/Sink Temperature v. Mean Forward Current.

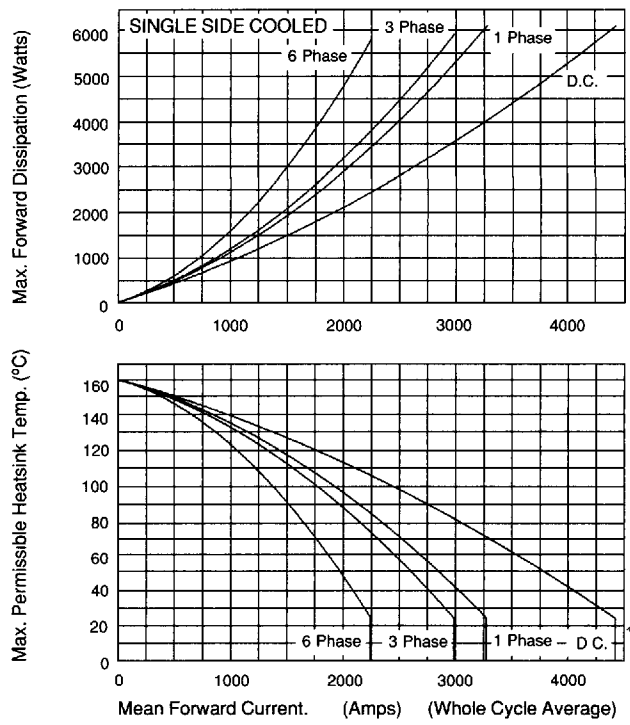
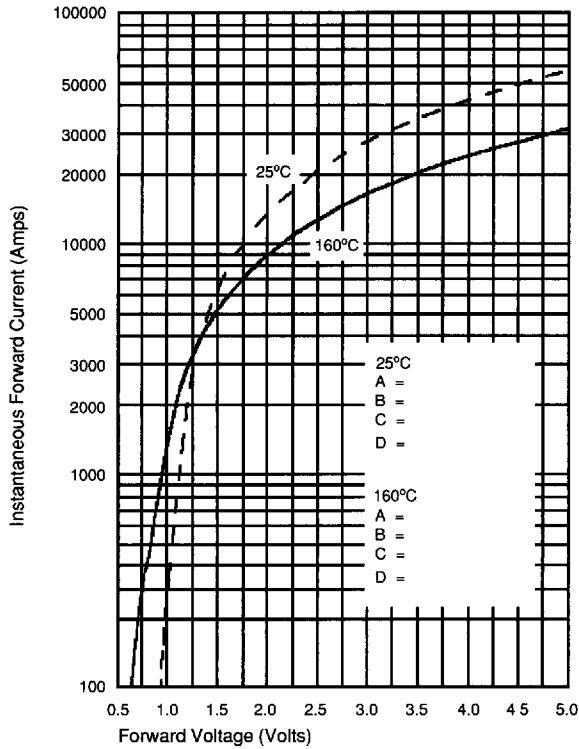

Figure 3. Limit Forward Characteristic at 160°C.



Forward volt-drop calculation :

$$V_F = A + B \ln I_F + C I_F + D \sqrt{I_F}$$

Figure 4. Junction to Sink Transient Thermal Impedance.

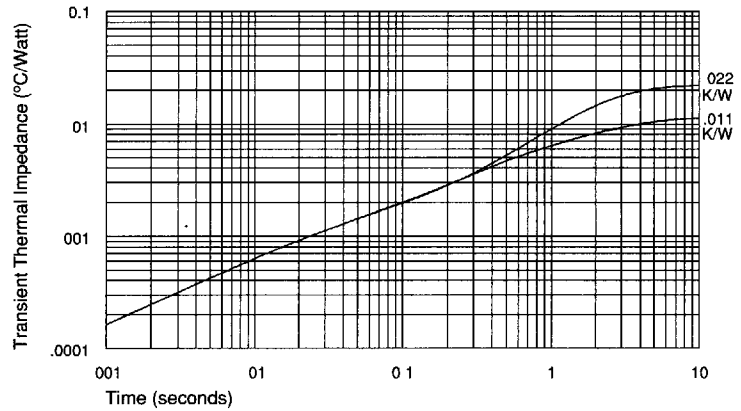
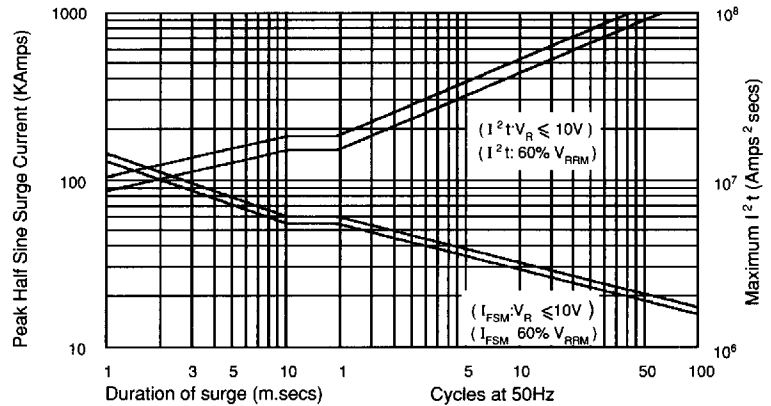

Figure 5. Non-Repetitive Surge Current at Initial Junction Temperature 160°C.



In the interest of product improvement, Westcode reserves the right to change specifications at any time without notice. © Westcode Semiconductors Ltd.



**WESTCODE SEMICONDUCTORS LIMITED**

P.O. BOX 57, Chippenham, Wiltshire, England SN15 1JL

Telephone (Sales) : (0249) 444524. Telex 44751.

Telefax : (0249) 659448